

Since 1961

Electrical India

ISSN 0972-3277

India's oldest magazine on power and electrical products industry



Electrical India Ranked Among World's Top 100 Publications in "The Future of Energy"

Energy Management and Conservation

EFFICIENCY

SAVING

GREEN

MANAGEMENT

CONSERVATION

ALTERNATIVE



- Smart Metering for Smart Monitoring
- Glimpse of Energy Meters



Power Distribution Systems in India



- Electrical Generators & Areas of Application
- Means of a Lithium-Ion Battery



Industry-proven Power Quality Solutions

From the switchgear company that **India trusts.**



Capacitor Duty Contactor



Power Capacitor



Thyristor Switching Module



APFC Controller



Active Harmonic Filter



Detuned Harmonic Filter

L&T Electrical & Automation, India's leading switchgear solutions company provides Power Quality management solutions that help industrial and infrastructural installations operate more efficiently.

The L&T PQS advantage:

- **Flexible options:** Widest range of capacitors for every need, with the latest addition of LTXL UltraHeavy duty capacitor in Cylindrical type
- **Optimized range:** Wide range of Capacitor Duty Contactors matching the corresponding capacitor rating to avoid oversizing of contactors
- **Fast capacitor switching** through reliable and compact Thyristor Switching Modules
- **Automatic, smart and optimized power factor control** through modular APFC controllers
- **Consistent power factor management alongwith operator safety** through type tested, customized panel solutions
- **Safeguard equipment** from harmonics related problems through Detuned Harmonic Filters and Active Harmonic Filters.

Customer Interaction Centre (CIC)

BSNL/MTNL (Toll free): 1800 233 5858 Reliance (Toll free): 1800 200 5858
Tel: +91 22 6774 5858 Email: cic@Lntebg.com



L&T Electrical & Automation

Regd. Office: Larsen & Toubro Limited, L&T House, N. M. Marg, Ballard Estate, Mumbai - 400 001, INDIA. CIN: L99999MH1946PLC004768

Scan the code to know more about our solutions for harmonic mitigation and their benefits



Energy Efficiency through Lighting Management

Features

- 2 Channel Detectors / Timers
- Wide range of detection
- Flush and Surface mounting

Manage the lighting applications in most efficient way with maximum comfort and flexibility.



Movement detectors



Presence detectors



Digital time switches



Analogue time switches

Hager Electro Private Limited
Office No. 504, Pentagon P 1, Magarpatta City,
Hadapsar, Pune-411013 India
Tel: +91 20 41477500 Fax: +91 20 41477510
Toll free no.: 1800 103 5440
Email: hagerwow@hager.co.in
hager.co.in

:hager



German Quality



Hello and welcome once again to *Electrical India*. There has been some not-so-good news for the Modi government in the recently-held bye-elections and also the two Lok Sabha seats. Of late, there have been advertisements on various radio and television channels about 100 per cent electrification of villages across the country. I have in my previous notes mentioned how statistics can be displayed in different ways as per ones convenience and liking. The way the government calculates the 100 per cent electrification of villages is itself faulty.

This is an election year and one can expect many more of such statistics. That's been the case government after governments. If the entire country is electrified, as is claimed by the government, then obviously no government in the future should talk of electrifying the villages. Mark my words! That will not be the case. In future too, there will be discussions and claims on electrifying our villages. Be that as it may, its one thing to have power for all on paper and second to have quality and consistent power. In short, power round-the-clock.

I was in Chennai last week and there was power failure in a big star hotel and gensets started immediately. The place from where this publication, strangely on the power industry, is published – Navi Mumbai, sees frequent power fluctuation and failures. It could be due to various reasons ranging from cable fault, cable cut due to different agencies working, transformer failure, load shedding etc. But the fact of the matter is how can industry function if such a situation exists even in a city let alone rural areas. Does it not cause unwanted pollution to the already-polluted cities because of use of diesel gensets? Same was the case in Dhule where there is power cuts quite regularly. This is a BJP-ruled state. Things are no different in several internal places in Andhra Pradesh, Rajasthan, Bihar etc, where there could be power shortage due to less availability of coal. Whatever, be the case, 'Make in India', irrespective of the party that rules, needs more power and continuous supply of power without any outages.

To end, I would like to quote from Brian Min's book, "Power and the Vote: Elections and Electricity in the Developing world." Indeed, the real test will be whether the government can ensure reliable supplies to the people, rather than simply taking power cables into people's homes. Hope you enjoy reading this issue as much as we have in bringing this to you. Please send in your comments to me on miyer@charypublications.in

Mahadevan

Publisher & Editor-In-Chief

Vol 58. Issue No. 6 • June 2018

Directors

Pravita Iyer
Mahadevan Iyer

Publisher & Editor-In-Chief

Mahadevan Iyer
miyer@charypublications.in

Editorial Department

Associate Editor

Supriya Oundhakar
editorial@charypublications.in

Sub Editor

Dhanya Nagasundaram
edit@charypublications.in

Editorial Co-ordinator

Nafisa Kaisar
nafisa@charypublications.in

Advertising Department

Director Advertisement

Pravita Iyer
pravita@charypublications.in

Advertising Manager

Yasmeen Kazi
yasmeen@electricalindia.in

Advertising Executive

Nafisa Khan
adv@electricalindia.in

Design

Nilesh Nimkar
charydesign@charypublications.in

Subscription Department

Priyanka Alugade
sub@charypublications.in

Accounts Department

Dattakumar Barge
accounts@charypublications.in

Sonali Pugaonkar

mktg@charypublications.in

Digital Department

Ronak Parekh
dgmarketing@charypublications.in

Chary Publications Pvt. Ltd.

906, The Corporate Park, Plot 14 & 15,
Sector 18, Vashi, Navi Mumbai 400703
Phone: 022 2777 7170 / 71

Single Issue: ₹ 100 / Annual Subscription: ₹ 1000

Disclaimer

Electrical India does not take responsibility for claims made by advertisers relating to ownership, patents, and use of trademarks, copyrights and such other rights. While all efforts have been made to ensure the accuracy of the information in this magazine, opinions expressed and images are those of the authors, and do not necessarily reflect the views/ collection of the owner, publisher, editor or the editorial team. Electrical India shall not be held responsible/ liable for any consequences; in the event, such claims are found - not to be true. All objections, disputes, differences, claims & proceedings are subject to Mumbai jurisdiction only.

Printed, Published and owned by Mahadevan Iyer from 906, The Corporate Park, Plot 14 & 15, Sector 18, Vashi, Navi Mumbai 400703 and Printed at Print Tech., C-18, Royal Indl Estate, Naigaum Cross Road, Wadala, Mumbai - 400 031. **Editor: Mahadevan Iyer**



Ultimate Solution

for Locating Faults

in all types of Power & Telecom underground Cables...



- Surge Generator up-to 32kV, 2000J
- Pre-location up-to 64km
 - TDR, ICM, SIM modes
- Pin Pointing
 - Simultaneous display of Acoustic & Magnetic waveforms
 - Also use as Route Tracer along with Audio Generator
- SIM Filter
- Cable Identification System
- Damp Discharge Rods
- Trolley mounted set up

Corporate Office

402, Aarus Chamber, Annex - A,
S. S. Amrutwar Marg,
Worli, Mumbai 400 013, INDIA

Phone : +91 22 4344 4244
marketing@scopetnm.com
Web Site: www.scopetnm.com



contents

Vol. 58 | No. 6 | June 2018

ARTICLES

- 26** Energy Management and Conservation
– Dr. Sarat Kumar Sahoo, Simran Bhalla
- 36** Smart Metering for Smart Monitoring
– Ashok Upadhyay
- 48** Electrical Generators & Areas of Application
– Mir Uzair Kanth
- 56** Means of a Lithium-Ion Battery
– Dr S S Verma
- 68** Power Distribution Systems in India
– Dr G D Kamalapur
- 76** Glimpse of Energy Meters
– Munazama Ali



FEATURES

- CT Analyzer for Current Transformer Testing & Assessment..... 44
- Mahindra Powerol Launches New Range of High Power Diesel Generators..... 81
- WAGO EPSITRON® – Advanced Power Supply System..... 82

INTERVIEWS



“Energy sector will hold center stage among growth drivers of economy”

52

Paul van Hinsberg
Sales Director
R. STAHL (P) Ltd.



“We have more than 33% market share”

74

N Balakrishnan
Managing Director,
EPCOS India Private Limited



DEPARTMENTS

- Publisher’s Letter 04
- News 08
- Appointments 20
- Awards 22
- Market Watch 24
- Product Avenue 83
- Statistics 87
- Index to Advertisers 89

A STEP AHEAD OF YOUR POWER NEEDS

Technology meets efficiency

Presenting
250 kVA & 320 kVA
Gensets



Equipped with advanced CRDe technology, these gensets are known for superior performance and better efficiency. It can withstand any climatic condition and is suitable for heavy duty applications.

Easy finance options available

Fuel Efficient & Rugged Engines | Best in class Block Loading Capacity | Smart DG with **DIGI SENSE** |
Over 400 Sales & Service Touch Points | Winner of Prestigious Deming Award 2014 & Superbrand 2015

PM Dedicates Kishanganga Hydro Power Station at Srinagar

Prime Minister Narendra Modi dedicated Kishanganga Hydro Power Station (330 MW) of NHPC to the nation. Event was



held at Sher-e-Kashmir International Convention Centre, Srinagar in the presence of N N Vohra, Governor, J&K, Mehbooba Mufti, Chief Minister of J&K, Central Ministers Nitin Gadkari, Dr Jitendra Singh and R K Singh. From the State of Jammu & Kashmir, Kavinder Gupta, Deputy Chief Minister, Sunil Kumar Sharma, Minister for Power Development, Nazir Ahmed Khan, Dy Speaker, Dr Farooq Abdullah, MP and Muzaffar Hussain Baig, MP along with Ajay Kumar Bhalla, Secretary (Power), Government of India, Balraj

Joshi, CMD, NHPC, Ratish Kumar, Director (Projects), NHPC, N K Jain, Director (Personnel), NHPC, M K Mittal, Director (Finance), NHPC,

Senior Central & State Govt. officers and other senior officers from NHPC were also present on the occasion.

Prime Minister complimented the entire team of Kishanganga Hydro Power Station for braving extreme weather conditions and surpassing geographical and geological conditions and termed the commissioning of the Power Station, as a major step towards meeting power requirements of J&K and other states. The Prime Minister thanked all concerned for their support in completion of Kishanganga Power Station. 

NTPC Signs MoU with Bihar Govt

With an aim to improve the performance of power sector in Bihar, a Memorandum of Understanding (MoU) was signed between the Government of Bihar (GoB) and NTPC at Patna in the presence of the Union Minister of State (Independent Charge) for Power and New & Renewable Energy, R K Singh and Chief Minister of Bihar Nitish Kumar. The MoU envisages transfer of Barauni Thermal Power Station (720 MW) to NTPC. In addition to this, Bihar State Power Generation Company's (BSPGCL) equities in Kanti Bijlee Utpadan Nigam Limited (KBUN) & Nabinagar Power Generating Company (Pvt.) Limited (NPGC) will also be transferred to NTPC.

All the three power generation facilities are envisaged to be transferred to NTPC from the effective date to be notified by Government of Bihar through a Statutory Transfer Scheme. The transfer of these power stations to NTPC will result in their optimal & efficient utilization, bring the tariff down and benefit the people of Bihar at large. Power from all the three-power station shall be available to State of Bihar as before after approval by the Ministry of Power, Government of India. Energy Minister of Bihar Bijendra Prasad Yadav; Principal Secretary, Department of Energy, Bihar Pratyaya Amrit and CMD, NTPC Limited Gurdeep Singh were among the dignitaries present at the occasion. 

Power Grid Sets Capex Target of Rs 25,000 cr for 2018-19

Power Grid Corporation of India Limited (POWERGRID) has signed Memorandum of Understanding for the year 2018-19 with Ministry of Power, Government of India. The MoU was signed by Ajay Kumar Bhalla, Secretary, Ministry of Power, Government of India and I S Jha, CMD, POWERGRID in the presence of senior officials from Ministry and POWERGRID.

The MoU includes various targets to be achieved by POWERGRID during FY 2018-19. Capex target for the year has been set as Rs 25,000 crore. Other targets in the MoU inter-alia include parameters

related to human resources, project management, R&D and innovation and other efficiency and operational performance parameters.

POWERGRID, a Navratna CPSE and the Central Transmission Utility (CTU) of the country, has been consistently receiving highest rating i.e. 'Excellent' under since signing of the first MoU in 1993-94. As on March 31, 2018, the company owns & operates over 148,800 ckt km of transmission lines, 236 EHV sub-stations with transformation capacity of more than 322,000 MVA. Availability of this gigantic transmission network has been consistently maintained over 99.5%. 



Our quality extrusions ensure that the substation distributes power intelligently.

For expert solutions in extrusions, trust Hindalco.



Hindalco's expertise lies in quality. Made from high-quality aluminium, our extrusions are preferred for their superior alloy composition and mechanical properties, which meet the most stringent performance parameters. Our expertise is backed by superior Wagstaff AirSlip® billet casting technology. Our extrusions are trusted for high-quality applications in Power, Electrical & Electronics applications. Our excellence is also backed by a team of dedicated experts who provide customised services. Expertise, in quality and service, makes Hindalco Extrusions the strength behind industries.



HINDALCO
EXTRUSIONS
EXPERTISE IS OUR STRENGTH

www.hindalco.com

R K Singh Lays Inaugurates Underground Cabling Project

RK Singh, Minister of State (IC) for Power and New & Renewable Energy, Government of India, laid the foundation stone of the Underground Cabling Project in the Kumbh area of Haridwar. The project is very significant as Haridwar is one of the most important pilgrimage sites in India and a large number of devotees visit this holy city round the year.

Speaking after the foundation laying ceremony, R K Singh said that millions of devotees come to Haridwar during Kumbh. This project will ensure the safety of pilgrims and enhance the aesthetics of the

divine city. The project will benefit the citizens of Uttarakhand by way of reduced electricity losses. Roads will also become wider once overhead electric poles are removed.

This project will be implemented in Haridwar under the Government's flagship scheme 'Integrated Power Development Scheme' (IPDS). Underground cables have several advantages e.g. – reduced losses, low chances of developing faults and low maintenance costs. Whereas overhead lines are vulnerable to lightning strikes which may lead to interruption. 

India-Japan Energy Dialogue Held in New Delhi

The ninth India Japan Energy Dialogue was held in New Delhi. Minister of State(IC) for Power and New & Renewable Energy, R K Singh, and Minister of Economy, Trade and Industry (METI) Hiroshige Seko signed a joint statement . Both Japan and India, as the third and the seventh largest economies respectively, recognized that having access to reliable, clean and economical energy is critical for their economic growth and in achieving this, both Ministers agreed on further strengthening of bilateral energy cooperation for energy development of both countries, while also contributing to worldwide energy security, energy access and climate change issues.

Both India and Japan with a view to implement Nationally Determined Contributions (NDCs) under the aegis of the United Nations Framework Convention on Climate Change (UNFCCC) recognized the importance of development and deployment of next generation technologies including hydrogen to realize de-carbonization. Both India and Japan appreciated the relevance of the grid stability given the high penetration of variable renewable energy. Both countries agreed to initiate the discussion towards development of Electric Vehicles (EVs) by collaborating with 'Policy dialogue on next generation/Zero emission vehicles'. 

NITI Aayog & ABB India Partner to Make India AI-Ready

The National Institution for Transforming India (NITI Aayog) and ABB India have signed a Statement of Intent (Sol) to support the Indian Government realize its ambitious vision of 'Make in India' through advanced manufacturing technologies that incorporate the latest developments in robotics and artificial intelligence. NITI Aayog will work with ABB to prepare key sectors of the economy, such as the power and water utilities sector, industries like food as well as the heavy industries sector; and the transport (rail and metro) and infrastructure sectors for digitalization, the Internet of Things (IoT) and Artificial Intelligence (AI). The initiative also covers the fast-growing segment of



Anna Roy of NITI Aayog and Sanjeev Sharma, Managing Director of ABB India, sign a statement of partnership

electric mobility. Jointly, NITI Aayog and ABB will work with government ministries, solicit feedback for areas critical to them and discuss solutions using industrial automation, and digitalization technologies.

"We are looking forward to learning more about practical applications of future technologies such as AI and IoT, especially, in streamlining governance and economic systems. This collaboration, which will include cross-sectoral understanding of digitalization at ABB's world class centers, will be key in driving progress of key sectors in India. This collaboration is meant to lead to actionable insights and focused plans," said Amitabh Kant, CEO of NITI Aayog. 



Reliable Power for a Sustainable World.



Riello UPS win
New Product Innovation Award 2015
FROST & SULLIVAN

Global Leaders in Uninterruptible Power Supply Systems

Riello: 1st European manufacturer to rate its product for Eco-Energy Level efficiency

- Riello is one of largest manufacturer of UPS System
- Complete range from 1kVA - 6400 kVA
- Riello Power India has delivered over 10000 successful installations in India & Indian subcontinent
- Technical Support Team at your service 365 days 24 x 7
- PAN India presence with offices in all major cities

When it comes to expertise in Uninterrupted Power supplies Riello Power India has it all

- IGBT Rectifier / IGBT Inverter with built in galvanic isolation transformer
- Advanced Battery Management
- Very Low Total Harmonic Distortion (THDi < 3%)
- High Input Power Factor > 0.99
- High Output 0.9 (High Watt)
- Overall efficiency upto 95%



318, 3rd Floor, Time Tower, MG Road, Gurgaon, Haryana – 122002
 Tel: +91-124-4727134 • Mob:07838552211 • Email: ups@riello-power.com • Web: www.riello-ups.in

nVent Launched in India

nVent Electric ('nVent'), a global leader in electrical connection and protection solutions, announced its launch in India as an independent, publicly traded company. The organization is a spin-off of Pentair plc (Pentair), a multinational diversified industrial company. nVent has a leading portfolio of electrical enclosures, electric heat tracing solutions, complete heat management systems, and electrical and fastening solutions that connect and protect critical systems across the globe where the cost of failure is high.

Its innovative electrical solutions help maximize customer efficiency, improve utilization, lower installation costs as well as the total cost of ownership

and minimize downtime. "With the completion of this spin, nVent has achieved a major milestone in becoming a more focused, global leader in providing electrical connection and protection solutions to customers around the world," said Beth Wozniak, nVent's Chief Executive Officer.

Beth Wozniak added, "We are going to be a fast-paced, dynamic growth company, focused on our customers and moving with velocity. I am proud to be part of the nVent team and am confident in the strategy and portfolio we have in place to deliver long-term shareholder value." nVent customers include commercial builders, energy companies, data centers and industrial manufacturers. 

Hartek Solar Launches Customised Rooftop Solar Kits

Hartek Solar, the rooftop solar division of Hartek Group, announced the launch of its customised rooftop solar kits. Designed as 5-10 kWp plug-and-play kits which can be installed in a matter of hours rather than days, Hartek Solar's customised small-scale solar solutions will benefit kanal houses, housing societies, nursing homes, small commercial establishments, hotels and micro, small and medium enterprises (MSMEs). Hartek Solar Founder-Director Simarpreet



Singh said the company plans to put up at least 100 such installations in residential, commercial and industrial categories in the next six months, targeting the Tricity as well as industrial clusters in Ludhiana, Baddi, Dera Bassi and Mandi Gobindgarh. Simarpreet Singh

said these plug-and-play kits, which will cater to both gross metering and net metering consumers, promise to be a game changer in driving the demand for rooftop solar. 

Sterlite Power Gets USD 47 mn Order from GS S Korea

Sterlite Power has received an order of US\$ 47 million from GS S Korea for supply of High-Performance Conductor (ACCC). The ACCC will be used for a new 400kv transmission line across a route length of 169-km on a Power Grid Company of Bangladesh project. ACCC is also used for reconductoring on existing electric power transmission lines as it can carry twice as much current as a conventional aluminium-conductor steel-reinforced cable (ACSR) cable of the same size and weight.

Manish Agarwal, CEO, Solutions Business, Sterlite Power said: "This is the largest ever global order for High Performance Conductor (ACCC) in this region and we are happy to partner with GS S Korea in the execution of this prestigious project. Significantly, we

were the first player to pioneer this technology in India in 2011. Today, our order book for ACCC is full for the next 6 months and we further expect to double the volume by focussing on the SAARC and other countries." Sterlite Power is a leading global developer of power transmission infrastructure with projects of over 10,000 circuit kms and 15,000 MVA in India and Brazil. With an industry-leading portfolio of power conductors, EHV cables and OPGW, Sterlite Power also offers solutions for upgrading, uprating and strengthening existing networks. The Company has set new benchmarks in the industry by use of cutting-edge technologies and innovative financing. Sterlite Power is also the sponsor of IndiGrid, India's first power sector Infrastructure Investment Trust ("InvIT"). 

Panasonic

LED

ILLUMINATE YOUR DIMENSIONS FOR A BETTER TOMORROW...



BASE LIGHT



LED DOWN LIGHT



COB DOWN LIGHT



SUSPENDED HIGH
BAY LIGHT



LED STREET LIGHT

COMPLETE LED LIGHTING SOLUTIONS



LED DOWN LIGHT

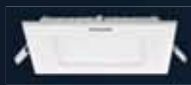

LED PANEL LIGHT



LED BULB



STRIP LIGHT



LED BATTEN LIGHT

Anchor Electricals Pvt. Ltd.

Regd. Office: 3rd Floor, B Wing, I-Think Techno Campus, Pokharan Road No 2, Thane (West), Thane - 400 607. Maharashtra
Customer Care Cell: 1800-103-8606 | Email: info@anchor-world.com | www.anchor-world.com | panasonic.net/ecosolutions/lighting/in/

A member of Panasonic Group

ReNew Power Acquires Ostro Energy

ReNew Power, one of India's leading clean energy companies, announced the acquisition of Ostro Energy. This strategic investment helps ReNew Power further consolidate its position in the fast-growing, Indian clean energy sector.

ReNew Power currently has green energy assets of more than 4500 MW, which include a commissioned capacity of approximately 2800 MW. Ostro Energy has a total capacity of more than 1100 MW, out of which nearly 850 MW is already commissioned. With the acquisition of these assets, ReNew Power's capacity will now exceed 5600 MW. Over 65 per cent of the combined portfolio capacity (ReNew Power and Ostro Energy) is already operational. ReNew Power's growth

has been mostly organic till now and it has grown into one of the leading energy companies in India in a span of seven years. This is the largest acquisition for the company till date and reinforces its already strong position in the Indian market. The addition of the Ostro team and assets to the ReNew family will further strengthen the company's vision of contributing to the Government of India's 2022 goal of 175 GW of renewable energy. Ostro has built an impressive business with diversified geographical spread; good quality infrastructure; and stable long term PPAs. Ostro Energy's assets are spread across Andhra Pradesh, Karnataka, Telangana, Rajasthan, Madhya Pradesh and Gujarat. 

BHEL Bags Order for Largest Hydro Power Project in Nepal

Amidst stiff international competition, BHEL has secured a prestigious order for executing 900 MW Arun-3 Hydroelectric Project from SJVN Arun-3 Power Development Company (SAPDC), Nepal. Notably, once completed, this will be the largest Hydropower project in Nepal. Located in the Sankhuwasabha, district, this project will substantially enhance Nepal's present installed power capacity and will contribute significantly to Nepal's vision of utilising its vast hydro potential for accelerated economic development.

This prestigious order is a testimony to BHEL's proven technological prowess in executing power

projects of this magnitude. The order will also provide a fillip to the company's focus on globalization as a driver for growth.

Valued at Rs 536 crore., the order envisages design, engineering, manufacturing, supply, erection and commissioning of electro-mechanical equipment involving supply of four Vertical Francis Turbines and Generator sets, each rated 225 MW. BHEL has been the flag bearer of Indian engineering across the globe for over four decades. Starting its journey with the first export order from Malaysia in the early seventies, the company has been expanding its references on a sustained basis. 

Vikram Solar Commissions its First Defence Sector Rooftop Solar Project

Vikram Solar, one of India's leading module manufacturer and a prominent rooftop solar & EPC solutions provider commissioned a 350 kW solar power project at Gun and Shell Factory (GSF) in Cossipore, Kolkata through roof-top installations. This is the first project that has been commissioned by Vikram Solar in the Defence Sector. GSF Cossipore is a unit of the Ordnance Factories Board that manufactures special equipment for the Indian Army. The project is spread across 4180 sq. Meter of roof top area that has 1130 modules powering five different buildings. The solar installation is expected to save 430 metric tonnes of carbon dioxide emissions.

Senior General Manager, GSF, mentioned, "Vikram

Solar's Rooftop EPC portfolio is vast and impressive and we are happy to associate with them and be part of the green energy drive. We felt responsible for the betterment of the environment and thus contributed to a sustainable future, wherein Vikram Solar has helped us in fulfilling this in a cost-effective manner. Despite stringent procedures and safety rules for entering and working inside the GSF premises and restrictions on work timings, the project development was carried out smoothly and as per all quality and execution compliances. I insist, that Vikram Solar assesses the feasibility of solar installations on various metal sheets and concrete roofs within the GSF premises for further capacity addition". 



ISOLGUARD

insulation monitoring device



HOSPITAL SYSTEM HIG95/E

For ungrounded networks

Surge
Protection
Device



Insulation
Monitoring
Device



Hakel spol. s.r.o.
Bratři Stefanu 980
500 03 Hradec Kralove
Czech Republic
t: + 420 494 942 300
f: + 420 494 942 303
e: info@hakel.cz
w: www.hakel.com



ALLIED POWER SOLUTIONS
(ISO 9001:2008 & UL listed LPS installer)
T - 4, 5 & 6, Third Floor, Pankaj Plaza - 3
I.P. Extn., Patparganj, Delhi - 110 092 (INDIA)
t: +91 11 2224 7322
e: info@alliedpowersolutions.com
w: www.alliedpowersolutions.co
Bengaluru: +91 98869 63195
Kolkata: +91 83348 95599

Duke Energy to Sell Five Hydroelectric Plants to Northbrook Energy

Duke Energy Carolinas (DEC) announced that through a competitive bidding process, it will sell five small hydroelectric plants in the Western Carolinas region to Northbrook Energy. The transaction will save customers money over time, while ensuring a continued source of clean energy. The facilities, which have a combined 18.7-megawatt generation capacity, are Bryson, Franklin and Mission hydro stations in the Nantahala area, and Tuxedo and Gaston Shoals hydro stations in the Green/Broad River Basin. DEC will



purchase all of the energy generated by these facilities for five years through power purchase agreements with Northbrook Energy. "This sale will deliver long-term benefits for our customers and shareholders," said Randy Herrin, Duke Energy Vice President,

Carolinas Regulated Renewables. "Over the past few years, the cost to operate these facilities has risen significantly. Through this transaction, the plants will continue to serve our customers with clean renewable energy, but at a lower cost." 

IBC SOLAR Completes Largest Ground-Mounted PV Installation in Turkey

The Turkish regional company of IBC SOLAR AG, a global leader in photovoltaic systems and energy storage, has commissioned a ground-mounted solar energy project with a total capacity of 11.4 MWp in the province of Mersin.



The project complements an existing 4.24 MWp rooftop installation, which IBC SOLAR Turkey has already completed in January 2018 for Tiryaki Agro. Hakan Daltaban, the Managing Partner of IBC SOLAR Turkey, stated: "Not only that we have completed one of Turkey's largest rooftop

projects, we now also have commissioned one of the largest ground-mounted PV installations. Mehmet Tiryakioğlu, board member of Tiryaki Agro, has supported these projects from their tender phases up to the commissioning stage. With his visionary perspective, he has sent out

a signal to other potential investors in the sector of solar energy." The project's design and installation was carried out by Turkish and German engineers from IBC SOLAR under the technical supervision of the Fraunhofer ISE Institute. 

GE Power Chosen to Lead EPC Contract for Ostroleka C Power Plant

GE Power was informed that it has been chosen as the lead EPC, in consortium with Alstom Power Systems, to build the ultra-supercritical (USC) coal power plant Ostroleka C in Poland. Subject to the financial closure of the project, the plant will start commercial operation within 56 months after the notice to proceed and generate a gross output of 1,000 MW, enough to power 300,000 homes in Poland.

In addition to co-leading the consortium, GE Power will design, manufacture and deliver its market-leading ultra-supercritical technology components for this new power plant. With USC technology, the plant will perform to the highest efficiency level possible for a steam power plant in Poland with 46% efficiency, well

above the global average of 33% efficiency. Each percentage point improvement in efficiency significantly reduces CO₂ emissions from coal power plants by over two percentage points. GE Power will also provide advanced environmental control systems such as electrostatic precipitators and wet flue gas desulfurization plant. These technologies ensure Ostroleka C will meet the most stringent emission requirement as called for by the latest European Union directive. "GE Power is pleased to have the confidence of Enea and Energa and is looking forward to partnering with them to build Ostroleka C. This plant will combine our EPC experience with leading coal-based technology," said Andreas Lusch, CEO of GE's Steam Power. 

SAFE WIRING SAFER BUILDINGS!

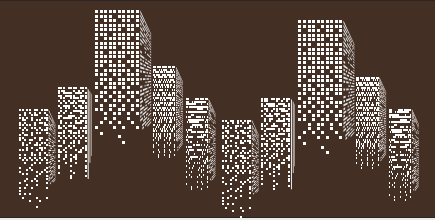

Its unique properties make the most secure, efficient and durable installations.

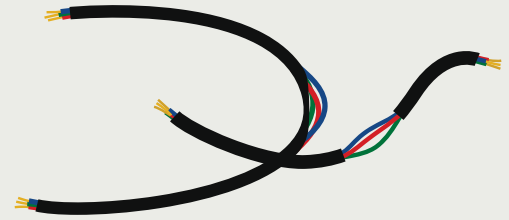

Electrical conductors are manufactured with high-purity (99.99%), electrolytic copper, which ensure major conductivity.

Copper is able to transmit quality energy at a low loss rate.

Copper wires and cables are capable of significantly reducing energy losses, thus contributing to low CO₂ emissions.

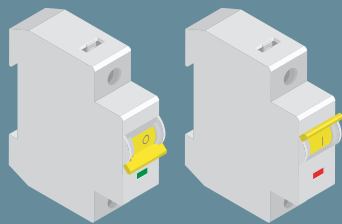
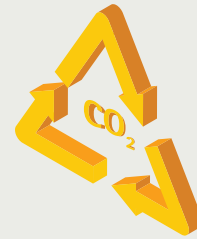

Copper is highly resistant to deformation and corrosion, thus, prolonging both the useful life and safety of products used in electrical installations.

Currently, copper is present in many devices such as circuit breakers, fuses, grounding rods, rails, switches and sockets.

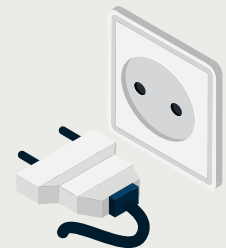

Having a safe electric installation is important because it:

Increases protection for both people and property



Reduces the potential for fires



Reduces the risk of electric shock



International Copper
Association India
Copper Alliance

**COPPER. MAKES THE
WORLD WORK BETTER**

Brad Sawatzke Named Energy Northwest CEO

Energy Northwest's executive board named Brad Sawatzke as the agency's chief executive officer. Sawatzke has been acting as interim CEO since the departure of Mark Reddemann. The board also appointed Grover Hettel as Chief Nuclear Officer. Hettel previously served as Vice President for Operations. Replacing Hettel as Operations Vice President is Bob Schuetz, who will also continue in his role as Columbia Generating Station's plant general manager pending selection of a new plant manager. In an organizational change, the EN Executive Board moved the agency's hydro, wind and solar operations, as well as new development and energy business

services, under the leadership of Brent Ridge.

"I am humbled and honored with this new opportunity," Sawatzke told the board. "We have a talented and capable team, and I'm very enthusiastic about the bright future facing us as a 100 percent clean generator of environmentally safe and affordable electricity." As CEO, Sawatzke leads an organization of nearly 1,100 men and women the most prominent of which is the Columbia Generating Station nuclear power plant. Columbia, near Richland, provides approximately 10 percent of Washington's electricity, or enough electricity to power one million homes. 

Power Products Acquires King Innovation

Power Products, LLC announces its acquisition of King Innovation. Based in O'Fallon, Missouri, King Innovation® is a recognized leader in the design and manufacture of innovative construction grade products for the irrigation, electrical, gas utility and landscape lighting markets. King Innovation will become part of Power Products' Electrical Construction and Maintenance Division (ECM).

"The acquisition of King provides us with a broad offering of innovative and proprietary products and supports our initiative to grow rapidly in the electrical channel and expand into adjacent channels. We are

very excited to welcome King's management and employees to the Power Products family," said David Scheer, CEO, Power Products. Mike Masino, President of the ECM Division, added, "The acquisition of King is a great addition to the ECM Division, and combined with Gardner Bender, Sperry Instruments, Bergen Industries, and Calterm, creates a unique strategic platform for our distributor, retailer, and catalog partners."

King Innovation will continue to operate its R&D, manufacturing, and all customer support functions from its headquarters in O'Fallon, Missouri under the direction of Frank Vlasaty, President. 

Spencer Group Hailed as Humber Green Energy Champion

Spencer Group has been recognised as a champion of green energy in the Humber. The Hull-based company was among the winners in the Humber Renewables Awards 2018, a celebration of achievement and innovation as the region becomes established as the UK's leading hub for low-carbon technologies. Spencer Group was named as Humber Renewables Champion in the awards staged by the Hull Daily Mail and Grimsby Telegraph.

The awards judges were impressed by Spencer Group's extensive green credentials, including excellent progress on two major renewable energy projects, as well as how it has played a leading role in developing a skilled future workforce and encouraging

women into the manufacturing and engineering sectors. The judges said: "A record year for infrastructure projects has seen a major waste from energy plant all but realised in the city, while this multi-disciplinary engineering company sends out talented technicians north to add further biomass capability for a regional giant. "The ambassadorial role in education, place marketing and women in manufacturing and engineering makes this a standout company with a clear conscience and pride in its roots." Spencer Group was also a runner-up in the Humber Renewables Medium/Large Business Award, which was won by North Lincolnshire-based Singleton Birch, the UK's leading independent lime supplier. 



GreatWhite[®]
THE FUTURE OF BRIGHT

HAR
DESIGN
MEIN
WOW

Add a futuristic look to your living spaces with beautifully designed titanium color switches & accessories. Experience our elegant accented switches, perfectly encapsulated in a flawless glass plate - adorned with a stylish chrome bezel. Sure to make you go wow.



myrah[®]

IMAGINATION UNLIMITED

Genex Appoints New CEO

Genex Power is pleased to provide stakeholders with an update on the company's board renewal and CEO succession planning strategy. This comes as Genex transitions from early stage development to implementation and delivery of the Kidston Renewable Energy Hub as well as expanding its focus on growing its project pipeline.

The Board is pleased to announce the appointment of James Harding as the Company's new CEO effective 7 May 2018. James was previously Genex's Executive General Manager since June 2016.



James Harding

In his 25 years' experience in the electricity sector, he has delivered major projects across the world. James was instrumental in timely delivery of the Kidston Stage 1 50MW Solar Project which was constructed on time and within budget. With James' appointment as CEO, co-founder and previous Managing Director, Michael Addison, will become a Non-Executive

Director effective the same date. Michael will remain active in the strategic direction of the company with a commensurate consulting role as a strategic adviser consulting on project delivery. 

Tata Power-DDL Appoints Sanjay Banga as CEO

Tata Power Delhi Distribution (Tata Power-DDL) announced the appointment of Sanjay Banga as the company's new Chief Executive Officer. Banga will take over from Praveer Sinha as he has been elevated to the position of CEO & MD of Tata Power.

Banga has been with the Tata Power-DDL since July 2003 and was part of the founding team which transformed the ailing distribution company into a benchmark utility. He has been serving as the Vice President - Power Management, Contracts and Business Development. He brings with



Sanjay Banga

him over three decades of experience in the power sector and worked on designing, project engineering, operations and commissioning of super thermal power projects. He has also extensively worked towards technology integration in the distribution space for ushering in sectoral reforms. Banga started his career with NTPC. He is also a Board of Director in Tata

Power Ajmer Distribution Limited, a Distribution Franchisee of Tata Power. Banga is an alumnus of the National Institute of Technology, Kurukshetra and an MBA Graduate from FMS, Delhi. 

ENGIE Appoints Yoven Moorrooven as CEO for Africa Business Unit

Yoven Moorrooven is appointed CEO of ENGIE's Africa Business Unit as of April 15th, 2018. He succeeds Bruno Bensasson who is leaving the Group. Yoven, a Mauritian national, holds a master's degree in econometrics and a master's degree in banking, finance and commodities. He began his career in 2003 at Gaselys (ex-joint-venture company between Société Générale and Gaz de France).

He spent three years in the company as a market economist and as an originator. In 2006, he moved into investment banking at the Macquarie Bank in



Yoven Moorrooven

London to develop its energy markets division. After five years, he became partner at Macquarie. In 2012, he moved to Deutsche Bank, where he was responsible for the management of its gas, power and coal origination and trading activities in Europe. Yoven joined ENGIE in 2013. Until 2016, he held the position of head of the International Division within the Global Energy

Management Business Unit, responsible for the development of all new energy market activities, and more specifically biomass valorisation in which the Group has acquired a worldwide leadership. 



HAVELLS

Next generation controller in user-friendly ATS



Advanced features of the controller:

- Programmable for both ATS and changeover applications
- Communication (start / stop) feature with DG
- Suitable for auto and manual modes
- Measurement of voltage (single phase / three phase)
- Inbuilt protection for mains against undervoltage / overvoltage and frequency

www.havells.com
marketing@havells.com



HAVELLS
CONNECT

Toll Free No.: 1800 11 0303 (Toll Free), 011-4166 0303
(Landline), 1800 103 1313 (All Connections).
For dealer interested in opening new Havells Galaxy Store,
please e-mail at: galaxy@havells.com

*Conditions apply.

NHPC Wins Laurels at India Pride Awards 2017-18

National Hydro Power Corporation (NHPC) Limited and its subsidiary NHDC Limited were awarded under various categories at the India Pride Awards 2017-18. NHPC was conferred with 'Excellence in CSR or Environment Protection and Conservation' award and NHDC was conferred with 'Excellence in Electricity and Power Category' award.



Amitabh Srivastav, Chief Engineer (CSR) and B P Rao, Chief Engineer (CSR), NHPC are receiving the award by Dharmendra Pradhan, Union Minister of Petroleum and Natural Gas and Skill Development and Entrepreneurship and Shivraj Singh Chauhan, Chief Minister, MP.

Chief Engineer (CSR) and B P Rao, Chief Engineer (CSR) from NHPC and by A G Ansari, CED, NHDC. The awards were presented by Dharmendra Pradhan, Hon'ble Union Minister of Petroleum and Natural Gas and Skill Development and Entrepreneurship along with Shivraj Singh Chauhan, Hon'ble Chief Minister, Madhya Pradesh at a glittering function at New Delhi on 28th March 2018.

The awards were received by Amitabh Srivastav,

function at New Delhi on 28th March 2018.

SolarEdge's Inverter Wins Accolades

SolarEdge Technologies was voted the Gold Winner for its HD-Wave inverter technology in the Renewable Energy Category by the Edison Awards, one of the premier awards program in the US recognizing innovation. SolarEdge joined some of the world's most recognized companies for the awards ceremony celebrating 31 years of honoring innovators and innovations. Applying a novel approach to inverter design, SolarEdge's HD-Wave technology represents a significant leap in the evolution of solar inverters.



This technology dramatically reduces the size and weight of the inverter's magnetics by means of advanced digital processing. The new technology also increases reliability and optimizes the performance of solar energy systems to reach record-breaking inverter efficiency of 99%.

This advancement enables more solar power to be produced at lower costs. "Our judges recognized SolarEdge as a true innovator out of the many products in its category," said Frank Bonafilia, Executive Director of the Edison Awards.

Acuity Brands Wins Design Excellence Awards

Multiple innovative LED lighting solutions from Acuity Brands earned top recognition from one of the lighting industry's most prestigious award programs: The LFI Innovation Awards® 2018.

Winning lighting solutions from Acuity Brands included:

- Juno FlexConnect™ luminaires won both the competition's overall Design Excellence Award and its Best of Category award in the Dynamic Color, Theatrical, Cover, Strips and Tape category.
- CHISEL™ family of luminaires from Mark Architectural Lighting (TM) won Best of Category in

the Commercial Indoor Luminaires category. CHISEL indirect, recessed luminaires present soft luminous gradients and textures that can bring depth and character to any design.

- Quantum® ELM2LF Fixed Optics emergency luminaires from Lithonia Lighting won Best of Category in the Industrial, Vandal Emergency and Exit category. The Quantum ELM2LF emergency luminaires combine the latest LED and optical technologies to deliver an easy to install wall-mount design featuring fixed optics. This design requires no contractor aiming, yet provides uniform distributions.



HAVELLS

Install Havells APFC Panel & save money by reducing kVAh



Why pay more due to low Power Factor?

Is there still a difference in kVAh and kWh in your Electricity Bill due to low Power Factor?

Features

- Manufactured with highly precise modern **Amada CNC Machine**
- **11 Tank Process** for corrosion proof powder coating
- Ergonomic, compact and robust design
- Designed with **100% Copper Conductor**
- **Heavy Duty Power Capacitor** for long life
- **Advance C-MOS Technology** based micro processor for intelligent power factor control
- **Air Core Reactor** for extra safety from inrush current
- Provision of top and bottom cable entry
- Automatic temperature control through fans and louvers in panel
- Double side earthing connection

www.havells.com
marketing@havells.com

 /havells
 /havellsindia

 /havellsindia
 /havells_india



HAVELLS
CONNECT

Toll Free No.: 1800 11 0303 (Toll Free), 011-4166 0303 (Landline), 1800 103 1313 (All Connections).
For dealer interested in opening new Havells Galaxy Store, please e-mail at: galaxy@havells.com

*Conditions apply.

EV Charging Stations Market to be worth USD 30.41 bn by 2023

India, one of the largest contributors of greenhouse gases, has pledged to phase out petrol and diesel cars by 2030. This initiative by the Indian government is expected to create a huge demand for EVs and EV charging infrastructure in the country...



Picture courtesy: commons.wikimedia.org

According to the new market research report by MarketsandMarkets, the electric vehicle charging stations market is expected to grow from USD 5.30 billion in 2018 to reach USD 30.41 billion by 2023 at a CAGR of 41.8% between 2018 and 2023. Key factors such as government funding, subsidies, and incentives, growing demand for electric vehicles, growing concern toward environmental pollution, and heavy investment from automakers of EVs are driving the electric vehicle charging stations market.

DC charging station to hold the largest share of the electric vehicle charging stations market between 2018 and 2023

The ability of DC charging stations to charge an EV in lesser time compared to AC charging stations is the primary driving factor for the high growth rate of former in the electric vehicle charging stations market. Also, the increasing popularity of public charging stations is boosting the demand for DC charging stations. Furthermore, automakers are planning to invest in DC fast charging network to support their launch of long-range battery electric vehicles (BEVs).

Commercial installation to hold the largest share of the electric vehicle charging stations

market between 2018 and 2023

The growth is attributed to an increased deployment of charging stations at public places such as shopping malls, commercial buildings, airports, and restaurants. The convenience of being able to use an EV charger while shopping or during office hours is expected to boost the adoption of electric vehicles. Furthermore, government offerings, such as tax credits, on the installation of publicly accessible stations are expected to boost the commercial installation of charging stations.

APAC held the largest share of the electric vehicle charging stations market in 2017

A majority of electric vehicle charging station installations in APAC are driven by huge demand in countries such as China and Japan. Currently, APAC is the largest market for electric vehicle charging stations globally. Furthermore, South Korea and India are taking initiatives to reduce greenhouse gas emissions by increasing the use of EVs. For instance, India, one of the largest contributors of greenhouse gases, has pledged to phase out petrol and diesel cars by 2030. This initiative by the Indian government is expected to create a huge demand for EVs and EV charging infrastructure in the country. Moreover, in September 2017, the Indian government decided to buy 10,000 electric cars from Tata Motors to replace old petrol and diesel cars used by government agencies. Furthermore, in September 2017, the Singapore Government launched its first large-scale EV car sharing program. Under the car sharing program, BlueSG (Singapore), a subsidiary of Bolloré Group, will install 500 charging stations equipped with 2,000 charging points in Singapore.



HAVELLS

More power and less energy consumption with Havells IE2 & IE3 motors



IE2 and IE3 Motors are equipped with AEG Technology ranging from kW/hp : (0.12-350)/(0.16-470), that are accepted worldwide for utilising energy efficiently. So your savings are generated automatically.

Features:

- All Aluminum Motors come with multi-mount construction and easy change of terminal box position (up to 160 frames)
- 6 Lead Terminal Box • Suitable for standard VFD drives • Low weight-to-output ratio • Better heat dissipation
- Cast iron motors from frame 80 to 355 with good aesthetics and surface finish

Wide range of Motors



Smoke Extraction Motor

Foot Mounted Motor

Flange Motor

Foot cum Flange Motor

Crane Duty Motor

Inverter Duty Motor

Brake Duty Motor

Prima Series



HAVELLS-LAFERT MOTORS

www.havells.com
marketing@havells.com



**HAVELLS
CONNECT**

Toll Free No.: 1800 11 0303 (Toll Free), 011-4166 0303
(Landline), 1900 103 1313 (All Connections).
For dealer interested in opening new Havells Galaxy Store,
please e-mail at: galaxy@havells.com

*Conditions apply.

Energy Management and Conservation

Energy management is a process by which a sector or an organisation can effectively manage how much energy they produce and how to control, monitor and conserve as much energy as they can while also generating enough energy to meet the demand of the customers...



Original Picture: www.pixabay.com

For the past few decades, energy generation has been shifted to alternative energy sources like renewable energy forms such as solar, wind and biomass energy etc instead of the conventional fossil fuel sources.

Apart from the growth in the energy sector, there has been an equivalent increase in businesses and organisations, which has brought tremendous competition in the market in terms of increasing environmental standards and

Figure 1: China and India account for about half of the world increase in Energy use

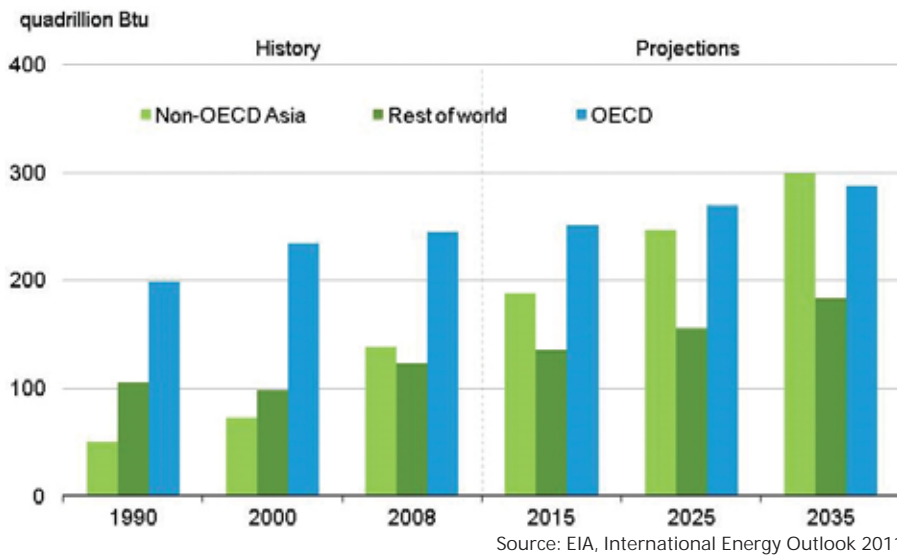

reducing global warming, carbon foot print and green house gas emissions. Energy management is a process by which a sector or an organisation can effectively manage how much energy they produce and how to control, monitor and conserve as much energy as they can while also generating enough energy to meet the demand of the customers. Apart from protection of climate and conservation of resources, another important factor when dealing with energy conservation is cost savings. The cost should be reduced in a manner such that the work processes are not affected. And thus, profit should be maximised by minimising costs.

According to a study released by the US Energy Information Administration in the year 2011, China and India were the two countries which were least affected by the worldwide recession. In the year 2008, both these nations accounted for 21% of the total world energy consumption. By 2035, both the countries will

account for 31% of world energy use in the IEO2011 Reference case. This is shown in the figure 1.

With these rising statistics, it is essential that we not only reduce energy consumption at private and public organisations, but also at homes, to save energy and thus, protect our environment and reduce carbon emissions as well. In 2016, India stood fourth worldwide, as the largest consumer of energy, the figure being double of that in 2000. It is also expected that nearly 315 million more

Indians will move to cities in the upcoming 25 years as the economy will grow and this in turn will lead to a rise in the energy demand.

A large amount of energy and money can be saved in general by employing energy management and the savings in any organisation can follow the profile as shown.

Low Cost Activities (First Year)	5 to 15%
Moderate Cost, Significant Effort (Three To Five Years)	15 to 30%
Long Term Potential, Higher Cost, More Engineering	30 to 50%

Table.1. Savings through Energy Management

As shown, huge amount of savings and paybacks can be achieved through energy management. It can also help companies by not only improving productivity but also the quality that they offer using energy efficiency techniques and better materials and manufacturing processes. The grouping of better quality, better products, lesser environmental damage, and lesser costs of energy provides bonus to the companies and in turn helps sustaining the environment and conserving the resources too.

Figure 2: India's Energy Demand

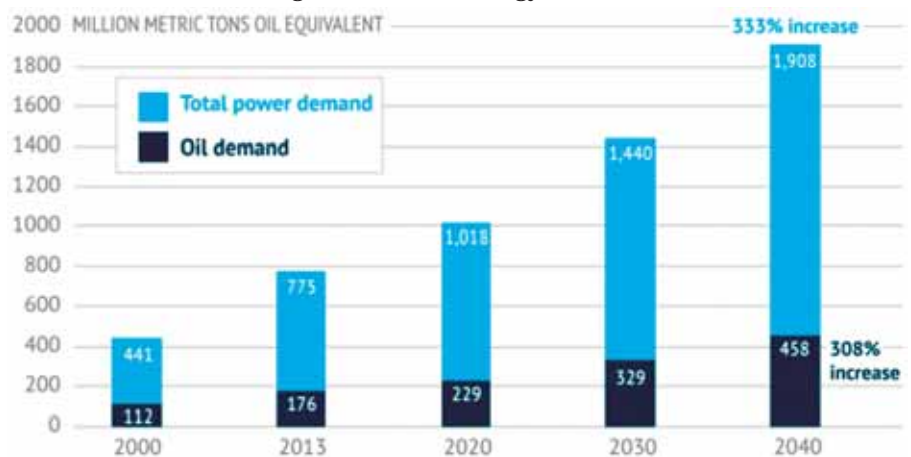

Source: IEA, World Energy Outlook 2015

Figure 3: Basic Block Diagram of an Energy Management System

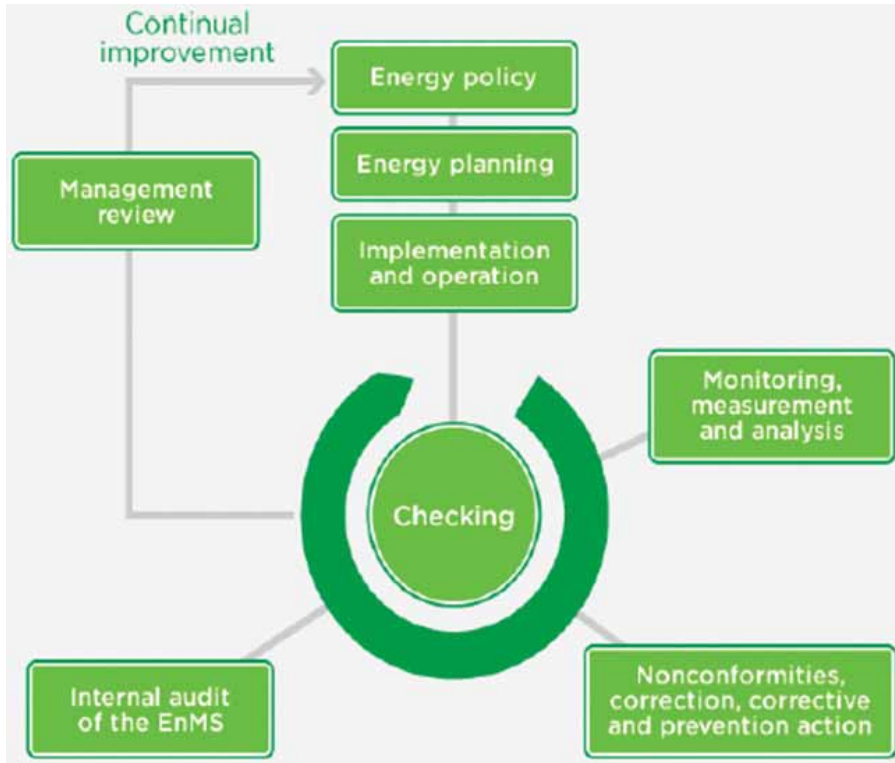

Information sourced from ISO 50001

Principles governing energy management are as follows.

1. Control the costs of the energy function, and not the Btu of energy. Since energy always provides a service, it is advisable to control the total cost than just the Btu of energy since the total cost is more closely related to the interests of the organisation.
2. The second principle is to control energy functions as a product cost, not as a part of manufacturing or general overhead. The energy functions should be a part of the costing system so that the specific impact of each function can be better judged.
3. The third principle is to control and meter only the main functions – which accounts for

only 20% functions which make up 80 percent of the costs.

4. The last principle states that the major effort of an energy management program should be put in to installing controls and achieving results. Each step of the process should be monitored to achieve appropriate results.

With the depletion of natural resources, switching to better options like smart grids and smart metering helps in reducing the amount of energy consumed and to also further increase the efficiency of these power systems, **Energy Management Systems (EMS)** are employed. It consists of a series of policy framework, processes and procedures to manage the energy usage. Therefore, EMS helps in maximising profits by reducing costs and

enhancing efficiency of the system.

An EMS can be interfaced with the grid through a **Supervisory Control and Data Acquisition System (SCADA)**, which can transmit thousands of measurements from a power system to an energy management system with real time data. With the increasing use of renewable energy, there are a number of challenges faced by the grid and to be able to sustain these challenges, energy management technologies need to consistently evolve. The same is needed at the distribution end also to be able to make it more integrated, when compared to the transmission system.

The ISO 50001 released an Energy Management Systems Standard in 2011 for more efficient use of available energy sources, and enhanced competitiveness along with reducing greenhouse gas emissions. This standard is applicable irrespective of the types of energy used. The basic block diagram of an Energy Management System is as shown in Figure 3.

When it comes to India, the nation's energy intensity per unit GDP is much higher when compared to Asia, USA or Japan, which indicates that energy is being used inefficiently and also that there is scope for conservation. A single unit of energy saved avoids 2.5 to 3 times of capacity augmentation. In India, there is a huge scope for energy conservation in each sector as shown in the Table 2.

Sector	Potential
Industrial	Up to 25%
Transport	Up to 20%
Agricultural	Up to 30%
Domestic and Commercial	Up to 20%

Keep your electricity flowing & business growing



Uninterrupted power supply is the goal of every power transmission and distribution company, but many problems lie in the path of achieving it. These problems can lead to unnecessary shutdowns, and can cause huge monetary and man-hour losses. To help power companies achieve highest efficiency, FLIR brings a wide range of thermal imaging cameras and T&M products.



Transformer Thermal Image



Substation Thermal Image

Images for illustration purpose only.



FLIR's wide range of products for predictive and preventive maintenance

These products help in detecting hot spots from a safe distance, avoiding unwanted shutdowns, identifying hazardous SF6 gas leakage, monitoring high voltage electrical substations continuously from remote location, etc.

For more information, call us at +91-11-4560 3555 or write to us at flirindia@flir.com.hk

FLIR Systems India Pvt. Ltd.

1111, D Mall, Netaji Subhash Place, Pitampura, New Delhi - 110034 | Fax: +91-11-4721 2006 | www.flir.in

[f/FLIR](#) | [t/FLIR](#) | [y/FLIR](#)



Figure 4: National Action Plan on Climate Change



set up in 2002, works at the central level, to assist the Energy Conservation Act. A large number of initiatives have been taken up by the Ministry of Power in alliance with BEE, like conservation of energy in areas like lighting at homes, commercial offices and buildings, labelling of appliances etc. With the Standards and Labelling programme, launched in 2006, the Bureau provided customers the right choice to save and conserve energy, and save costs too. The main aim is to reduce the amount of energy consumed by the appliance without a compromise in the service. Other programmes include Energy Conservation Building Codes (ECBC) to set minimum energy standards for commercial complexes with a connected load of 100kW.

The Demand Side Management (DSM) Scheme was also initiated for agriculture, Municipal, DISCOMs and Small and Medium Enterprises (SMEs) sector. It is essential to inculcate energy

Economy as a whole	Up to 23%
--------------------	-----------

Table 2: Sector Wise potential for Energy Conservation

Taking into consideration the potential of energy conservation, the government has launched various plans to start the drive of energy management and conservation. The Government is not only promoting greater use of renewable energy sources such as solar and wind but is also working towards ultra – super critical thermal power plants, which will run on an indigenous technology helping to reduce the carbon footprint. Aimed to be set up in Chennai, it is expected to be completed by 2024. The plant will generate 800 MW at operating temperature of 710 degree Celsius and 310 bar pressure of steam.

Equal efforts are being put into the demand side through various policies like the Energy Conservation Act of 2001. The Bureau of Energy Efficiency (BEE),

Figure 5: NMEEE- Four new Initiatives

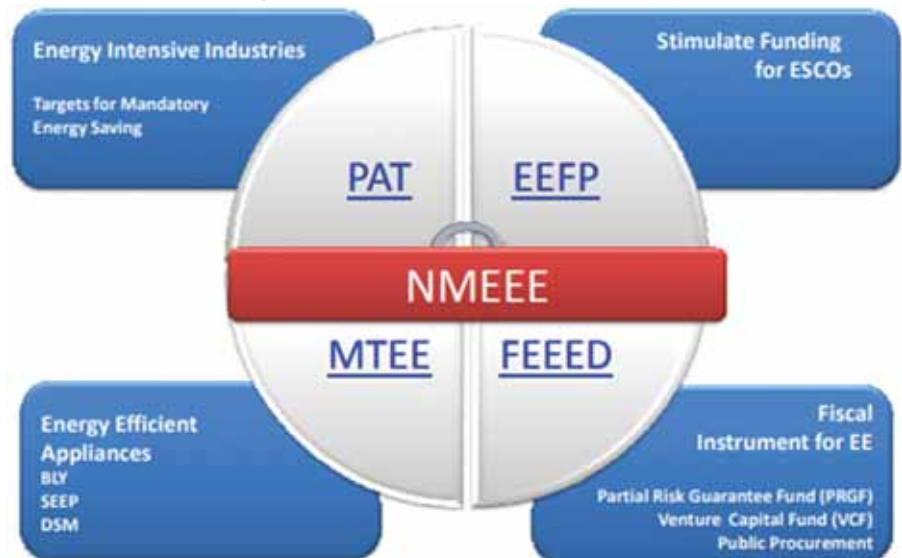

efficiency in the agriculture sector because it still remains one of sectors having a very high contribution to the GDP. Apart from Agriculture, the scheme was also implemented in Urban Local Bodies (ULBs) for substantial savings in power consumption. Capacity Building of DISCOMs was another essential aspect of the scheme to carry out effective energy conservation and management. Energy Efficiency was also implemented in selected 25 SMEs to assess energy use and technology gap. With the initiation of the XII plan, 100 projects in 5 SMEs are up for demonstration.

The implementation of the Energy Conservation Act in the states, carried out by **State Designated Agency (SDAs)**, was set up in 32 states, and the Ministry of Power financed these institutions for strengthening their process of energy conservation.

The **National Mission for Enhanced Energy Efficiency (NMEEE)** is one out of the eight enlisted missions under the National Action Plan on Climate Change (NAPCC). The main objective is to strengthen energy efficiency for sustainable business models by an appropriate mixture of Energy, Efficiency, Equity and Environment. The four initiatives under NMEEE are:

1. **PAT – Perform, Achieve and Trade** – mainly to increase the effectiveness of cost in Industries
2. **Market Transformation for Energy Efficiency (MTEE)** – To accelerate the change to Energy Efficient appliances
3. **Energy Efficiency Financing Platform (EEFP)** – To assist finances in the demand side management programmes
4. **Framework for Energy Efficient Economic Development (FEEED)** – Development of fiscal instruments for the promotion of energy efficiency.

Under MTEE, two other programmes – namely **Bachat Lamp Yojana** and **Super Efficient Equipment Programme (SEEP)** have also been launched in which over 29 million incandescent bulbs have been replaced by CFLs. Under SEEP, efficiency of ceiling fans has been aimed to be increased by over 50% than the current market average, with average lives of over 15 years. BEE also intends to prepare material on Energy Efficiency which will be included in the NCERT textbooks for grades 6th to 10th in order to promote energy efficiency in schools as well. In this context, the government is promoting the efficient use of energy

Attracting Tomorrow 



TDK Technology Advancing power solutions.

Rare-earth magnets
with high magnetic
field strength for wind
power generators



**Varistors and
surge arresters**
with high surge
capability



**EMC filters and
sine-wave filters** for
currents up to 8 kA



**Aluminum electrolytic
and film capacitors**
for high ripple currents





product.tdk.com/en/industrial

Analysis

at homes encouraging the use of LEDs. This scheme was initially called Domestic Efficient Lighting Program and now relaunched as UJALA.

Conclusion

The per capita energy consumption is small compared to the average of other countries which have a high human development index. However, India is bound to achieve the basic quality of life, which will also increase the CO₂ emissions. In order to achieve low carbon emissions and keeping in pace with the global scenario, every service, may it be lighting, mobility or cooling, will have to be more energy efficient. And to achieve this, the areas where major savings

can be made have to identified and technological interventions to achieve energy efficiency in all sectors will be necessary. Contribution of public and increased awareness, along with holistic policy environments directed by BEE, can incentivise energy efficiency effectively. Today, energy efficiency is yet to appeal to a large section of industries and the lack of benchmarks does not encourage its promotion. The demand for energy in India has been consistently increasing and there is enormous potential within sectors for energy conservation. The various policies in the recent years have been effective in reducing costs of systems, conserving energy. Some

technologies might be immature and there may be certain benefits which have gone unnoticed. But despite these drawbacks, India can continue to be a surplus nation with concentration on renewable energy sources, smart technologies and promoting energy efficient solutions with proper energy management and conservation. 



Dr. Sarat Kumar Sahoo

Professor/HOD
School of Electrical
Engineering, VIT University,
Vellore, Tamilnadu.



Simran Bhalla

Student
School of Electrical
Engineering, VIT University,
Vellore, Tamilnadu.

Visibility defines a long term impression

Media does the first entry to opening your door in the mind of your clients

Advertise in
Electrical India

Contact Yasmeen at
+91 22 27777 7196
+91 9867914216



FROM PRINT WORLD TO THE E-WORLD

ELECTRICAL INDIA ENHANCES LIFE WITH ENGINEERING EFFICIENCY

**BESIDES MONTHLY
MAGAZINE, TAKE ADVANTAGE
OF THE DIGITAL TECHNOLOGY
& READ ELECTRICAL INDIA
MAGAZINE ONLINE, AS WELL AS
WEEKLY E-NEWSLETTER
ON YOUR PC, TABLET OR LAPTOP.**

**FOR SUBSCRIPTION PLEASE
CONTACT PRIYANKA ON
022-27777182/8652142057 OR
Email on sub@charypublications.in**

Please turn back for the subscription form.

**To Advertise, in Electrical India
newsletter/magazine please
contact YASMEEN on
022 2777 7196 / 9867914216
or email on
yasmeen@electricalindia.in**

Since 1961

Electrical India

India's oldest magazine on power and electrical products industry

SUBSCRIBE

Since 1961
Electrical India
 India's oldest magazine on power and electrical products industry

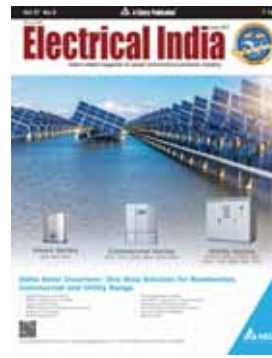

Subscription Offers

Sub. Period	No. of Issues	Subscription Type					
		Print		Digital		Print+Digital	
		Actual Rate	You Pay	Actual Rate	You Pay	Actual Rate	You Pay
1 Year	12	1200.00	1000.00	1200.00	1000.00	2400.00	1500.00
2 Years	24	2400.00	1750.00	2400.00	1750.00	4800.00	2625.00
3 Years	36	3600.00	2500.00	3600.00	2500.00	7200.00	3750.00
5 Years	60	6000.00	4000.00	6000.00	4000.00	12000.00	6000.00
E-Newsletter							
1 Year	52	N. A.		365.00		N.A	

PLEASE SELECT MODE OF DISPATCH FOR PRINT EDITION -
 (1). By REGISTERED PARCEL - Rs. 435/- year (2). By COURIER - Rs. 600/- year
KINDLY ADD POSTAGE CHARGES IN SUBSCRIPTION AMOUNT.

Subscription / Renewal Form

To,
 The Subscription in-charge
 ELECTRICAL INDIA
 Email: sub@charypublications.in

Are you a Subscriber,
 Please submit your Subscription no:

Yes, I would like to Subscribe/renew Electrical India / EI e-Newsletter for _____ years at ₹ _____.

PAYMENT DETAILS :

Cheque / DD No. _____ Dated _____ Drawn on Bank _____
 _____ Branch _____ in favour of Chary Publications Pvt. Ltd.

Bank details for NEFT / RTGS / IMPS : Account Name: Chary Publications Pvt. Ltd.

Bank Name: Bank of India Branch: Chembur, Mumbai - 400 071 Account Type: Current Account
 IFSC Code: BKID0000009 Bank A/C Number: 000920110000322 SWIFT CODE :BKIDINBBCHM

Name: _____

Company: _____ Designation: _____

Address: _____

_____ City: _____ Pin: _____

Telephone: _____ Mobile: _____

Email: _____

Signature: _____

Stamp

 **Chary Publications Pvt. Ltd.**

905-906, The Corporate Park, Plot No. 14 & 15, Sector 18, Opp. Sanpada Railway Station, Vashi, Navi Mumbai - 400 703.
 Phones: +91 22 27777 170 / 171 • Email: sub@charypublications.in • Contact : Priyanka Alugade • +91 22 27777182 / +91 8652142057



TRUEPOWER
EARTHINGS PVT LTD
 An ISO 9001:2000 Certified Company

SAFETY BEYOND IMAGINATION

- ★ CHEMICAL EARTHING
- ★ ESE LIGHTNING ARRESTER
- ★ COPPER BONDED ROD
- ★ EARTH PIT COVER
- ★ POLY PLASTIC EARTHING
- ★ PIT COVER
- ★ SPIKE LIGHTING ARRESTER



MAINTENANCE FREE CHEMICAL EARTHING

Approved by:



True Power Earthings Pvt. Ltd.

Office No. 15, 2nd Floor, Ankur Chambers,
 Opp. Prakash Dept Store,
 Tapkir Galli, Next to Vasant Talkies, Pune - 411002
 Ph : 9370335298 / 020-65400097
 Email : pune@truepowerearthings.in

www.truepower.co.in, www.truepowerearthings.com

Smart Metering for Smart Monitoring

The better outage management increased remote monitoring on power losses and controlling them and accurate billing are most important advantages of smart meters using AMI. Smart meter has a great role in smart grid and is considered as most important for future energy management..



The Government of India's initiatives like 'Make in India' and 'Smart Cities' need the efficient, reliable and continuous power supply. India's power sector in the present day is facing a lot of problems like AT & C losses, inefficient distribution and transmission system because of age old infrastructure and power theft. The advanced energy management and increased use of renewable energy resources are the foremost areas to concentrate by governments for the development of country. The government cannot take initiatives for complete change of electrical equipment across the country but there is a need for changing the way of operation and control of the electrical equipment.

Energy meters are a key component of a power supply system and play a significant role in revenue protection, quality control, compliance with regulatory

requirements, consumer satisfaction and image building. Energy meter measures the amount of electrical energy consumed by a domestic consumer or a commercial consumer. There are basically two different types of energy meter, namely electromechanical type energy meter and electronic energy meter. The present billing systems have many problems like problem of payment collection, energy thefts, quality of photographs that is printed on bill etc. due to which the traditional billing system is slow, costly and unreliable. The present billing system has chances of error and it is also time consuming. In the existing meter system, consumers are presented with usage information only once a month with their bill.

A smart energy meter is typically electronic equipment that record and store consumption data of energy in intervals of an hour, minute or less and communicates that information at least daily back to the utility for monitoring and billing purposes. Smart meters enable two-way communication between the meter and the central system. Unlike home energy monitors, smart meters can gather data for remote reporting. The smart meter is very important constituent for smart grid and is expected to provide cost-effective, social and ecological advantages for various stakeholders. The most significant key factors that determines the success of the smart meters is data analysis that deals with data acquisition, communication, processing and elucidation that benefits to

consumer, utility company and government.

The role of metering in the power sector is growing in importance. A complete metering system is imperative for improving the financial health of the power distribution companies. Inadequate and faulty metering has led to lower revenue and higher losses. Besides helping distribution utilities in managing revenues, meters have become a key source of valuable consumer information. Advance metering infrastructure, automated meter reading, pre-paid meters and net meters are the key technologies of smart metering being adopted. These meters allow a two-way exchange of information, automated processes such as meter reading, and enabling accounting of the electricity drawn from the grid by a consumer. This has helped in improving metering efficiency, billing accuracy, revenue management and consumer satisfaction.

Government Initiatives

Electricity Act, 2003 mandated distribution utilities for supply electricity to all the consumers, within stipulated time, through installation of a correct meter in accordance with regulations to be made in this behalf by the Central Electricity Authority. Over the last one and half decade, utilities have invested significantly in improving metering coverage in order to reduce their aggregate technical and commercial losses. Most of the states have achieved 100 percent metering for domestic, commercial and industrial consumers. However, some

distribution companies are yet to electrify all the house-holds in their regions and a large number of consumers, therefore, still remain unmetered in their states. With respect to feeder and distribution transformer metering, a large number of these remain to be metered and there is significant scope for improvement.

Metering in India received a major boost under the government's flagship scheme for AT&C loss reduction, the Restructured Accelerated Power Development and Reforms Program which was rolled out in 2007. The government through various policies such as the Integrated Power Development Scheme, the Deendayal Upadhyay Gram Jyoti Yojana and UDAY is aiming at 100 percent metering in the country.

One of the commitments under UDAY is to make the installation of smart meters compulsory for all consumers using more than 200 kWh of electricity per month. UDAY envisages fast track roll out of 35 million smart meters by the end of 2019. The target is to install smart meters for consumers with a monthly consumption of 500 kWh and above in first phase by 31st December' 2017 and the consumers with a monthly consumption of 200 kWh and above in second phase by December' 2019. UDAY also provides for compulsory feeder and Distribution Transformer metering, consumer indexing and GIS mapping.

The Integrated Power Development Scheme targets the installation of around six million

meters at the consumer, feeder and Distribution Transformer levels. The Deendayal Upadhyay Gram Jyoti Yojana with its focus on rural electrification, also target the installation of around 12 million meters at the consumer, Distribution Transformer and agricultural feeder levels. These schemes are also expected to provide significant opportunities for meter manufacturers. Under UDAY, awareness campaigns are also being organized to improve collection efficiency.

Need of Smart Metering

The smart meter is future for power industry and serves as an interface between consumer and the utility company. The smart meter records the power usage of consumer and communicates this data in a timely manner to utility center. For smart meter, it is very essential to collect precise and appropriate data in a timely manner which includes gathering of data, its communication and storage. The smart meter allows the bi-directional flow of information from consumer to utility and vice versa. The systematic analysis from the data acquired will lead to many prospective decisions by utility center that assures the efficiency and reliability of smart grid. This allows the utility center for better monitoring and control. The data communication in real time basis allows the utilities with advantages like real time pricing, outage detection, identification of power theft, avoids meter data tampering and provides better service. With the data received in timely manner utilities shall have a better

opportunity to work better with increased stability.

Smart meters can definitely cut the domestic or commercial energy consumption by giving a lot of useful information to the consumer, but this information is useful only if consumer looks into it. Smart meter gives best home energy management solutions for smart homes using wireless technologies like. Several sensor and actuators based appliances are commissioned in smart buildings to manage the connection of electrical load remotely based on the consumer choice or utility decisions envisaging the necessity of the smart meter.

Smart metering is also essential for strengthening the power distribution segment. Efficient metering practices help to maintain the financial health of a utility. These include accurate billing and prevention of power theft, which have been the focus areas for utilities. These practices also help in lowering aggregate technical and commercial losses of the utilities. Transition from electromechanical meters to electrostatic meters was one of the first step towards improving consumer metering.

Smart Metering Practices

Now the utilities are adopting smart metering, prepaid metering, net metering etc. and focusing in meter data analysis. Some of the new and smart metering practices being adopted by utilities are as follows:

i. AMR and AMI Metering

Automated Meter Reading is being adopted as it provides

advanced capabilities like outage management, data analytics, tamper detection and network management to utilities. Meter data management and analytics are also developed by utilities for enhanced customer services, theft detection and power quality monitoring, better understanding of consumption patterns and energy efficiency.

The idea of smart grid increases the efficiency of power usage by the introduction of bi-directional flow of information from utilities to consumer and vice-versa. This can be possible by the introduction of 'Advanced Metering Infrastructure (AMI)'. The information about electrical consumption of a consumer is recorded in a timely manner and this data is aggregated and analyzed by 'smart meter' installed at consumer premises. The analyzed data is communicated to utilities using AMI. Smart grid using smart metering and AMI technologies establishes the wide area monitoring, protection and control.

AMI adoption is likely to accelerate further, as such system provide a vast range of facilities like load management and outage handling, remote meter reading, remote connecting and disconnecting as well automated and timely billing.

ii. Net Metering

There is a growing focus on solar rooftop projects in the country. With the rapid growth of the rooftop solar segment and the ambitious targets set by the government for this segment, net metering assumes a critical role. It

Attracting Tomorrow



BIS Compliance: With EPCOS Capacitors.

We offer superior solutions for motor run and motor start:
World-class EPCOS AC capacitors, manufactured in state-of-the-art
automated production facilities.

**Our capacitors are already available with ISI marking.
Get them now and comply with statutory requirements.**

www.global.tdk.com · www.epcos.com

EPCOS India Pvt. Ltd. · A TDK Group Company

Mumbai: 022-25 75 08 00 · Noida: 0120-4 50 58 01 · Kolkata: 033-24 19 88 15 · Bengaluru: 080-40 39 06 40 · sales.in@epcos.com

is necessary for the discoms to provide net metering facilities to consumers, which allow the consumer to feed electricity into the grid. To this end, the regulators have issued net metering policies or regulations. This presents a major opportunity for manufacturers of bi-directional meters that track the energy consumed and generated by consumers, and enable net billing. In order to meet the target set by the government for rooftop solar, the adoption of net meters is likely to increase further in the coming years.

iii. Prepaid Metering

Prepaid meters operate on a no use no pay principle, wherein consumers pay for their electricity consumption in advance. It improves collection efficiency, reduces working capital requirements for utilities and provides greater flexibility to consumers while budgeting consumption. In prepaid metering, the meter manufacturer provides meters with prepaid billing software based on the tariff set by the utility. Most of the states have developed prepaid meters, but the development has been limited to selected consumers segments. It is used for temporary connections as well as in areas where utilities face uncertainty of payment.

The cost of three phase prepaid meters is more than three to four times the cost of an ordinary meter. Utilities are required to overcome the cost hurdle through rental payments and regulators are required to allow utilities to collect rental charges from consumers for prepaid metering.

iv. ToD (Time of Day) Metering

Pricing Time of Day metering is a billing method in which depending on the expected load on the grid, a billing day is divided into several time zones. The duration of each time zone is programmable and the user can define the time zones as per his requirements. The meter records the energy consumed in different time zones in separate registers and exhibits accordingly. Consumption in each of the time zone is charged at different rates. The tariff rates for different time zones are fixed in such a way that a consumer pays more for energy used during peak hours than for off peak hours. It becomes the responsibility of the consumer to either restrict his energy usage or pay accordingly. This encourages consumers to shift load during cheaper time periods of the day.

Limitations of Smart Meter

While the development of new smart metering technologies has increased, it is still slow, owing to the lack of adequate infrastructure with the utilities and their poor financial health. Some of the limitations for development of smart metering practices are as follows:

- i. One of the challenges in the adoption of smart meters is their high cost. Besides, there is a lack of clarity as to who will bear the cost burden.
- ii. There is need to develop checks and standards for smart meters. Along with laboratory testing of meters to check for their compliance, it is important for the utilities to undertake

checks for performance and reliability.

- iii. A key consideration in the adoption of smart meters is the identification of the target consumers group to accordingly undertake meter modifications.
- iv. A key concern for utilities is lack of efficient communication technologies. While distribution networks are often not capable of managing power line communication, RF communication finds limited uptake owing to a number of geographical limitations.
- v. There is also a lack of a mechanism for the testing of communication technology for meters. In automatic meter reading for feeders and high tension consumers, where meter reading is undertaken through modems, there are lot issues with the service providers/ telecom players.
- vi. Other limitations in the adoption of new metering technology includes disposal of old meters. The utilities have been grappling with the issue since the time electrostatic meters replaced electromechanical meters.
- vii. In order to promote the adoption of rooftop solar, bidirectional meters are needed. There are certain techno economic challenges impeding the rooftop solar projects like high investment, tariff slabs for buy-back of power, operation hours of rooftop plant etc.
- viii. There are however significant infrastructural development



www.ERDA.org

ONE STOP DESTINATION FOR DISTRIBUTION TRANSFORMER TYPE TESTING

Transformer Testing & Evaluation Services:

- Distribution Transformer as per IS:1180-2014
- Power Transformer as per IS:2026 & IEC:60076
- Paper Covered Copper & Aluminium Conductors
- High Voltage Bushings (up to 66 kV) & Insulators (up to 245 kV)
- CRGO Steel Laminations
- Evaluation of Solid Insulating Materials (Paper/Pressboard/Laminated Wood and boards/Cork sheets/etc.)
- Transformer Oil (New & In-service) & Dissolved Gas Analysis (DGA)

Testing Capabilities:

All tests as per IS:1180-2014

Routine Test

- Routine tests as per IS 2026

Type Testing

- Lightning impulse test as per IS 2026 (Part 3)
- Temperature-rise test as per IS 2026 (Part 2)
- Short-circuit withstand test as per IS 2026 (Part 5)
- Pressure Test

Special Test

- Determination of sound levels as per IS 2026 (Part 10)
- Short-circuit withstand test as per IS 2026 (Part 5)
- No load current at 112.5 percent voltage
- Paint adhesion tests. The test is performed as per ASTM D3359 (Standard Test Methods for measuring adhesion by Tape test)
- BDV and moisture content of oil in the transformer (IS 335)



ELECTRICAL RESEARCH AND DEVELOPMENT ASSOCIATION

ERDA Road, GIDC, Makarpura, Vadodara - 390 010, Gujarat

Toll Free No.: 1800 233 2668 • E-mail: bd@erda.org



Certificate No.: TC-5389

Analysis

and capacity building issues which need to be addressed before planning a large-scale implementation of the smart metering projects.

- ix. Given to uncertain demand of net meters, it is not in interest of the discom to maintain a stock of high-costing net meters at its end. However, making supplying sufficiently net meters available in a timely manner is a challenge.
- x. Lack of consumer awareness on Smart Grid concepts, such as how they will be benefited through smart metering.
- xi. Insufficient regulatory focus and policy on smart metering; and lack of system modification to enable the benefits of existing intellectual meter.

Way Forward

Unless the above issues are addressed properly, large-scale investment for smart metering will be an additional burden without realizing the benefits of revenue enhancement. The policy makers and regulators have to implement a robust incentive model framework to attract more and more private investments assuring the rate of return.

Also there is need for bringing in metering as a service, wherein a technology provider extends the metering facility to the utility and the latter makes payments for the

services availed of. This would relief the utility of the cost and risks involved in the implementation of new metering technology. Once the new technology has been successfully operated in its distribution area, the utility can deploy the technology on its own.

The implementation of projects on a turnkey basis by meter manufacturers will help overcome issues of interoperability and compatibility between communication technology and metering infrastructure. Besides, in order to keep pace with emerging technologies in a cost effective manner, it is required to develop universal meters which could be upgraded to new technology merely by updating the software.

For covering all the consumers to provide smart meters in next five years, the massive investment required for distribution companies those are suffering poor financial condition. In order to overcome this problem, financial institution like PFC and other nationalized banks would buy smart meters and communication devices from manufacturers and lease them to discoms against a monthly rent for a particular period. Implementation agencies should also be appointed which would be responsible for the overall implementation and

maintenance of AMI.

Development of domestic capacity to produce meter components can go a long way in reducing per meter costs for the country. Quality meters at competitive prices, consumer awareness, deployment of new technology and adequate maintenance of metering infrastructure should be the key focus areas for utilities.

Conclusion

The main objective of smart meters is for assuring the systematic energy management with the active participation of end user by coordinating utility companies in making intelligent decisions. The smart grid will enhance the stability and reliability of power systems using AMI technologies. The better outage management increased remote monitoring on power losses and controlling them and accurate billing are most important advantages of smart meters using AMI. Smart meter has a great role in smart grid and is considered as most important for future energy management. 



Ashok Upadhyay

Dy. Director (Generation)
M.P. Electricity
Regulatory Commission
Bhopal (M.P.)

Become the new face of growing technology

Read **Electrical India** for

- Technological updates
- Tending news from the industries
- Versatile topics covered
- Eminent writers from industries



To Subscribe, Contact Priyanka at +91 22 2777 7182 or email at sub@charypublications.in



**STILL USING
INSULATION
TAPE FOR WIRE
CONNECTIONS?**

Switch to WAGO 221

**COMPACT SPLICING CONNECTORS
For All Wire Types**

- Nominal current: 32 A
- Nominal Voltage: 450 V
- Can be used for higher temperatures:
 - Continuous service temperature:
max. 105 °C
 - Ambient operating temperature:
max. 85 °C (T85)



EASY • FAST • SAFE

WAGO Private Limited

C-27, Sector 58, Phase-III, NOIDA-201301, Phone: +91-120-4388700, 4369800, Fax: +91-120-2580081
Email: info.india@wago.com, Website: www.wago.com/global

CT Analyzer for Current Transformer Testing & Assessment

OMICRON's CT Analyzer was unique right from the start. It was the first device to facilitate effective on-site tests on current transformers (CTs). And there is still no other device available that allows comprehensive CT tests with accurate results within an operationally safe range of only 120 V. In addition, it weighs only 8 kg (17lbs).

To keep the device's technology at the high level required by its continuously changing working environment, the CT Analyzer has been reworked once again. We are proud that we can now show the results.

Improved Functionality

CT Analyzer's sensitivity and its application range have been improved. You can now perform accurate excitation characteristics measurements of CTs with a wide knee-point range between 0.1 V and 40 kV. This makes the CT Analyzer an even better tool to test all different types of CTs, from small metering devices to large protection CTs typically installed in power equipment such as power transformers.

New Operating Software CT Analyzer Suite

The new CT Analyzer Suite is a complete redesign of the operating software supporting you through every single step of the testing process. During test preparation, you can make the necessary test and asset-related entries in the structured software form. Before test



execution, wiring diagrams help you check the correct wiring of your measuring setup. Immediately after the tests you get an overview of the test results and an automated assessment of the CT condition.

Customized CT Assessment

To date the CT Analyzer allowed a CT assessment to be carried out according to all CT relevant international

standards. In order to carry out an assessment which goes beyond the international standards (IEC, IEE), the new CT Analyzer Suite offers you the flexibility to define and use local national standards (for example Canadian or British standard) as well as your own corporate standards or assessment rules for all important CT parameter (such as ratio error, phase displacement, transient parameters, dynamic current range and burden-dependent CT performance).

Additionally, OMICRON offers the facility to create such individual assessment rules based on your own requirements.

New accessories

The CT Analyzer also gets some new, helpful accessories for transport and operation.

The new multi-functional transport case is a heavy-duty option with wheels and serves as a "sturdy outer housing". All control elements of the CT Analyzer are on the front, allowing the device to be left in the case while testing. The lid is designed to be raised for use as a bench for a laptop while the CT Analyzer stays in the case. Attachable end plates can be used for mouse control or technical documents and offer further space for accessories.

The new backpack is a smaller and lighter carrying option with wheels, extendable handle and shoulder straps. It is designed for simple mechanical protection. 

Source: www.omicronenergy.com/ct-analyzer

HEY!

YOUR SEARCH
ENDS HERE



WOULD YOU LIKE

to know more about the HVAC and R (heating, ventilation, air-conditioning and refrigeration) industry.

JUST FLIP OVER AND WE HAVE A
SUBSCRIPTION FORM FOR YOU.

BESIDES MONTHLY
MAGAZINE TAKE
ADVANTAGE OF THE
DIGITAL TECHNOLOGY
& READ COOLING INDIA
MAGAZINE ONLINE, AS
WELL AS FORTNIGHTLY
E-NEWSLETTER ON YOUR
PC, TABLET OR LAPTOP.



PRIYANKA

022-2777182 / 8652142057
sub@charypublications.in



Chary Publications

Cooling India

India's foremost Monthly dedicated to the growth of HVACR Industry

YOU CAN ALSO
SUBSCRIBE **ONLINE**
www.coolingindia.in

SUBSCRIBE

Cooling India

India's foremost Monthly dedicated to the growth of HVACR Industry



Subscription Offers

Sub. Period	No. of Issues	Subscription Type					
		Print		Digital		Print+Digital	
		Actual Rate	You Pay	Actual Rate	You Pay	Actual Rate	You Pay
1 Year	12	1200.00	1000.00	1200.00	1000.00	2400.00	1500.00
2 Years	24	2400.00	1750.00	2400.00	1750.00	4800.00	2625.00
3 Years	36	3600.00	2500.00	3600.00	2500.00	7200.00	3750.00
5 Years	60	6000.00	4000.00	6000.00	4000.00	12000.00	6000.00
E-Newsletter							
1 Year	24	N. A.		365.00		N.A	

PLEASE SELECT MODE OF DISPATCH FOR PRINT EDITION -

(1). By REGISTERED PARCEL - Rs. 435/- year (2). By COURIER - Rs. 600/- year

KINDLY ADD POSTAGE CHARGES IN SUBSCRIPTION AMOUNT.

Subscription / Renewal Form

To,
The Subscription in-charge
COOLING INDIA
Email: sub@charypublications.in

Are you a Subscriber,
Please submit your Subscription no:

Yes, I would like to Subscribe/renew Cooling India / CI e-Newsletter for _____ years at ₹ _____.

PAYMENT DETAILS :

Cheque / DD No. _____ Dated _____ Drawn on Bank _____
_____ Branch _____ in favour of Chary Publications Pvt. Ltd.

Bank details for NEFT / RTGS / IMPS : Account Name: Chary Publications Pvt. Ltd.

Bank Name: Bank of India Branch: Chembur, Mumbai - 400 071 Account Type: Current Account

IFSC Code: BKID0000009 Bank A/C Number: 000920110000322 SWIFT CODE :BKIDINBBCHM

Name: _____

Company: _____ Designation: _____

Address: _____

_____ City: _____ Pin: _____

Telephone: _____ Mobile: _____

Email: _____

Signature: _____

Stamp

 **Chary Publications Pvt. Ltd.**

905-906, The Corporate Park, Plot No. 14 & 15, Sector 18, Opp. Sanpada Railway Station, Vashi, Navi Mumbai - 400 703.

Phones: +91 22 27777 170 / 171 • Email: sub@charypublications.in • Contact : Priyanka Alugade • +91 22 27777182 / +91 8652142057



Technology of Measurement... defined

Our Metering Product Range

- Digital Panel Meters
- Multi Function Meters
- Load Managers & Demand Controllers
- Single / Three Phase, Whole current counter/LCD type meters
- LT Trivector Meters
- Prepaid Metering Solution
- LPR (Zigbee) Metering Solution
- Data Acquisition & Billing Solutions



HPL serves wide range of metering solution with the commitment to modern technology. Offers range of meters with its Digital Panel Meters, Digital Energy meters, Multifunction Meters, Load Managers, Demand Controllers, Power Quality Meters with Metering solutions based on the wired and wireless technology such as Zigbee, GSM/GPRS etc.

Other Product Range



ëbrit Range of Digital Panel Meter



Dual Source Multi-function Load Manager



Emfis range of Multi-function Meter



Power Factor Control Relays



LCD Mini



Trivector Meter



ISO-27001:2005



ISO-9001:2008
ISO-14000:2004



HPL Electric & Power Ltd
enquiry@hplindia.com, hpl@hplindia.com
Ph.: +91-120-4656300 | www.hplindia.com

Customer Care No.
1800 419 0198

Electrical Generators & Areas of Application

In electricity generation, a generator is a device that converts motive power (mechanical Energy) into electrical power for use in external circuit. Sources of mechanical energy include steam turbines, gas turbines, water turbines, internal combustion engines and even hand cranks...

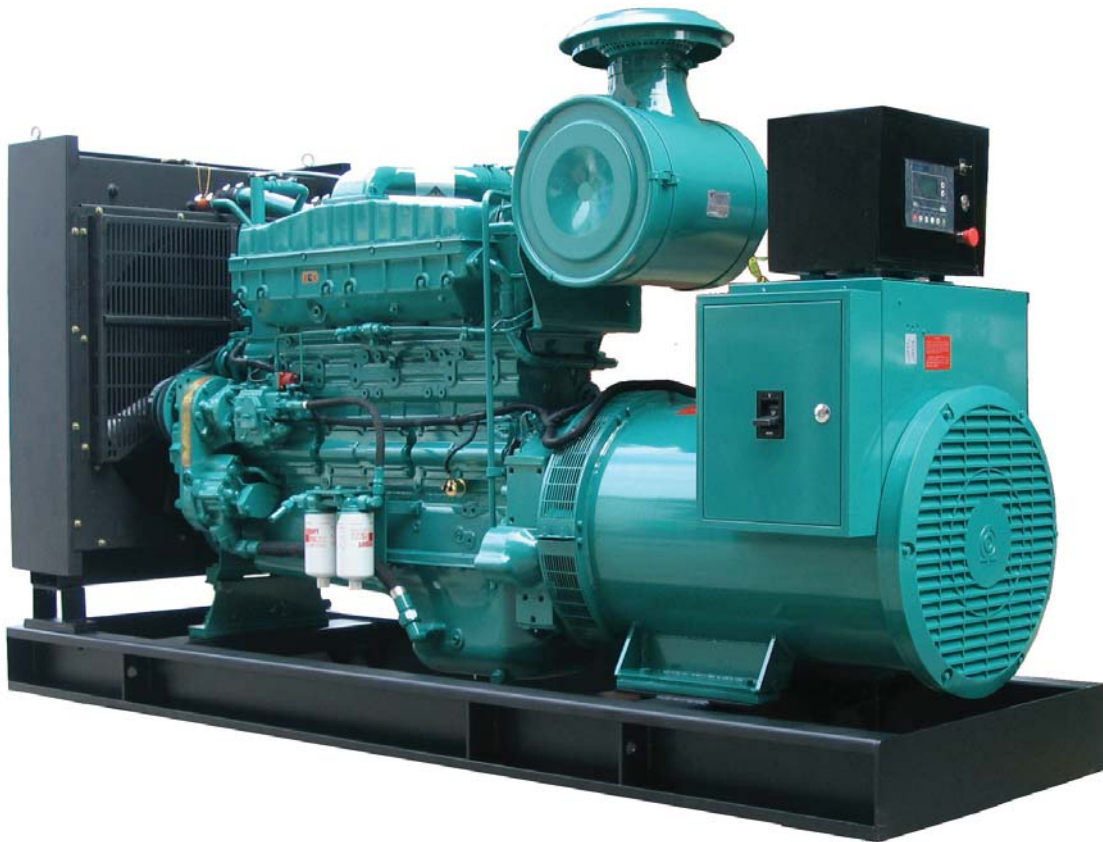

Photo: Abdul Aziz Abdo; commons.wikimedia.org

In electricity generation, a generator is a device that converts motive power (mechanical energy) into electrical power for use in external circuit. Sources of mechanical energy include steam turbines, gas turbines, water turbines, internal combustion engines and even hand cranks. The first electromagnetic generator, the Faraday disk was built in 1831 by

British scientist Micheal Faraday. Generators provide nearly all of the power for electric power grids.

Alternating Current

Synchronous Generator or Alternators

These are rotating machines that rotate at a fixed speed fixed by the supply frequency and number of poles in the magnetic circuit. These convert mechanical power from the prime-mover to an AC electric power at a specific voltage and frequency. A synchronous generator rotates at constant speed called synchronous speed. Synchronous generators are usually three phase, because of several advantages of three phase generation, transmission and distribution.

- The cost of transmission is less than for the same voltage and power in a single phase system
- A three phase generator has a 180% greater capacity than a single phase generator of same physical size.
- Single-phase voltage and power is easily available from a three phase system by merely tapping any two of power leads.

Alternator consists of two parts rotor and stator. Stator is the stationary part which carry armature winding in which EMF is induced, output is taken from the stator. The rotor is the rotating part. It produces the main field flux. The rotor field winding may be supplied by DC generator whose shaft is coupled to the rotor shaft of same alternator. The power rating of this DC generator may vary from 2%-5% of the power rating of the same alternator. The

rotor employed may be sailent type or cylindrical type. Sailent type rotor has field poles projected from the rotor surface. These type of rotors usually have large radius and short axial length. Sailent type of rotors are usually employed in low speed turbines due to their noisy operation in high speed applications. Usually, sailent type of rotor configuration is used in all hydro-generators. Cylindrical rotor has field poles distributed all over its outer periphery. About 66% of the rotor periphery is slotted and the unslotted regions represent field poles. This type of rotor has small diameter, but long axial length. Hence, it is suitable for high speed applications.

AC generator could employ either rotating armature or rotating field configuration, but selection of one over the other completely depends upon the size and capacity of alternator. Rotating armature AC generator are typically used in applications involving small amount of power. With large amount of power, larger amount of current may flow through the slip rings and brushes. It is difficult to and expensive to build slip rings and brushes to carry large amount of currents. Therefore, most large AC generators are rotating field generators.

Alternators are natural source of reactive power. Load current flows in stator circuit as EMF is induced in it due to rotating rotor magnetic field. As the current flows in armature winding located in stator, the armature field so produced may effect the main field and the effect is known as armature

reaction. This armature reaction may be magnetizing, de-magnetizing or cross magnetizing depending on the load power factor.

Induction Generator

Induction AC motors may be used as generators, turning mechanical energy into electric current. Induction generators operate by mechanically turning their rotor faster than the synchronous speed, giving negative slip. A regular AC asynchronous motor usually can be used as a generator without any internal modifications. Induction generators are useful in applications such as mini hydro power plants, wind turbines, or in reducing high-pressure gas streams to lower pressure, because they can recover energy with relatively simple controls. They do not require an exciter circuit because the rotating magnetic field is provided by induction from the stator circuit. They also do not require speed governor equipment as they inherently operate at the connected grid frequency. To operate, an induction generator must be excited with a leading voltage; this is usually done by connection to an electrical grid, or sometimes they are self-excited by using phase correcting capacitors.

Linear Electric Generator

In the simplest form of linear electric generator, a sliding magnet moves back and forth through a solenoid - a spool of copper wire. An alternating current is induced in the loops of wire by Faraday's



Magneto Hydrodynamic Generator

law of induction each time the magnet slides through. This type of generator is used in the Faraday flashlight. Larger linear electricity generators are used in wave power schemes. Almost all wave energy devices proposed so far utilizes conventional high speeds, rotary generators to convert mechanical energy into electricity. Several imaginative solutions have been developed to accomplish the conversion of the wave's bouncing motion to the rotary motion demanded by the generator. These power take off schemes are expensive both to construct and to maintain and they are often very vulnerable to extreme weather.

The main difference of a linear generator to conventional generator is that the motion of the rotor is linear which makes it possible to couple motion directly to the reciprocating, vertical motion of the waves which eliminates the need of the complex power take off scheme and gear boxes. The system consists of

abuoy, floating on surface of the ocean connected with a row to the rotor i.e. a piston with permanent magnet the piston, in turn is moving in coil where electricity is induced.

Variable Speed Constant Frequency Generators

Many renewable energy efforts attempt to harvest natural sources of mechanical energy (wind, tides, etc.) to produce electricity. Because these sources fluctuate in power

applied, standard generators using permanent magnets and fixed windings would deliver unregulated voltage and frequency. The overhead of regulation (whether before the generator via gear reduction or after generation by electrical means) is high in proportion to the naturally-derived energy available. New generator designs such as the asynchronous or induction singly-fed generator, the doubly fed generator, or the brushless wound-rotor doubly fed generator are seeing success in variable speed constant frequency applications such as wind turbines or other renewable energy technologies. These systems thus offer cost, reliability and efficiency benefits in certain use cases.

Direct Current

Homopolar Generator

A homopolar generator is a DC electrical generator comprising an electrically conductive disc or cylinder rotating in a plane perpendicular to a uniform static

magnetic field. A potential difference is created between the center of the disc and the rim (or ends of the cylinder), the electrical polarity depending on the direction of rotation and the orientation of the field. It is also known as a unipolar generator, acyclic generator, disk dynamo, or Faraday disc. The voltage is typically low, on the order of a few volts in the case of small demonstration models, but large research generators can produce hundreds of volts, and some systems have multiple generators in series to produce an even larger voltage. They are unusual in that they can produce tremendous electric current, some more than a million amperes, because the homopolar generator can be made to have very low internal resistance.

MHD Generator

A magneto hydrodynamic generator directly extracts electric power from moving hot gases through a magnetic field without the use of rotating electromagnetic machinery. MHD generators were originally developed because the output of a plasma MHD generator is a flame, well able to heat the boilers of a steam power plant. The first practical design was the AVCO Mk. 25, developed in 1965. The U.S. government funded substantial development, culminating in a 25 MW demonstration plant in 1987. 



Mir Uzair Kanth
 Assistant Professor,
 Department of Electrical
 Engineering, Islamic
 University of Science and
 Technology, Jammu &
 Kashmir



Innovative Cable Solutions



105 °C LV & MV XLPE Cables



No worries for cable overloading

Apar Industries Ltd, a Rs 5,000 Cr (USD 800 million) company has presence in Transformer/Specialty Oils, Overhead ACSR/AAAC & HTLS conductors and a wide range of Electrical & Telecom cables.

Apar offers several innovative products, one of them being higher temperature rated XLPE cables. If the ambient temperature is about 48-50 °C during summer (like in North India), or

say 50-55 °C in desert areas, then 90 °C rated XLPE cables need to be de-rated significantly, or a higher cross section is used.

Thanks to new development of 105 °C rated XLPE LV and MV cables, you can now safely relax and need not worry about any overload conditions during summer. The product is ideal for Solar industry, north based Utilities in India and Middle East region.

ELECTRICAL

- PVC Cables upto 3.3 kV
- XLPE Cables upto 66 Kv
- LT & HT ABC Cables
- Instrumentation Cables
- Concentric Cables
- Flexible Cables & Wires
- FR/FRLS/LSOH
- Fire Survival Cables
- Under water Cables

E-BEAM

- Ship Wiring Cables
- Locomotive Cables
- Solar PV Cables
- Wind Mill Cables
- Control & Flexible Cables
- PVC Winding Wires
- Automotive Wires
- Specialty Cables

ELASTOMER

- Trailing Cables
- Locomotive Cables
- Ship Wiring Cables
- Wind Mill Cables
- Welding Cables
- Mining Cables
- LFH Cables & Wires
- Fire Survival Cables
- EPR, Silicon & EVA Cables

TELECOM

- Optical Fiber Cables
- Armoured Optic Fibre Cables
- Torpedo Cables
- Tow Cables
- Indoor Telephonic Cables
- Composite Cables with OFC
- Fire Survival Cables OFC
- Cat 3/Cat 5 LAN Cables
- Railway signaling Cables

APAR INDUSTRIES LTD. (UNIT: UNIFLEX CABLES)

12/13, Jyoti Wire House, 1st Floor, 23A, Shah Industrial Estate, Off. Veera Desai Road, Andheri (W),
Mumbai – 400 053 (India), Phone: +91-22-26740001 / 26740002 / 26740003
Fax: +91-22-26740600 | E-Mail: info.cable@apar.com

“Energy sector will hold center stage among growth drivers of economy”



R. STAHL is a global leader in the field of explosion protection. R. STAHL designs, manufactures and supplies world-class products and solutions that assures uncompromising safety to people and assets even in the harshest environments. R. STAHL with the widest range of offering will continue to be a dominant player with increasing customizations, informs **Paul van Hinsberg, Sales Director, R. STAHL (P) Ltd.** in an interaction with **Electrical India...**

What solutions are offered by the company catering to industrial sector?

R. STAHL is a leading supplier of explosion protection electrical and instrumentation products and solutions. And when it comes to system specific safety to meet complex requirements, we are the market leaders in providing project engineering for customer specific flame proof protection. We provide incredibly reliable protection for people, machinery and the environment. Our expertise in industrial safety cuts across diverse industrial segments such as oil & gas, chemical, marine & ship building, pharmaceutical, food & beverage to name a few. In specific industries such as chemical and petrochemical, crude oil, natural gas extraction, pharmaceutical, paints, food & beverage - gases, vapors, mist and dust are generated during the production processes. When these mix with the oxygen in the air, it creates an explosive atmosphere

and ignition may result in catastrophic damages.

R. STAHL's comprehensive portfolio comprises of 7,000 products such as

- Lighting
- Automation
- Installation and Control Equipment
- Operating and Monitoring Systems (HMI)
- Camera Systems
- Signalling devices and alarms

All our products have international certifications such as ATEX, IECEX and national approvals such as PESO (selected products) and KLPL.

What evolutions have you witnessed in Indian Industrial sector when it comes to safety?

As the world's energy requirements continue to grow, the need for flame proof systems inherently grows as these requirements are met by natural gas and crude oil. R. STAHL being an integral specialist in this domain

has the most fitting and pertinent offerings in anti-explosion product range.

From a regulatory paradigm, explosions in various countries have prompted governments to introduce higher safety standards and tougher explosion protection laws and regulations. With a robust portfolio of offerings in the form of consultation, services and products, R. STAHL offers its customers protection for both people and systems hardware.

The growing global population has led to an increasing demand for food which has largely contributed to the growth of food and beverage industries. We need a catalyst line here to connect growing FMCG needs and the dust generated in these production units.

R. STAHL provides dust explosion protection solutions for these applications. In the current scenario, pharmaceutical companies are not only conducting research into new active ingredients, but they also try to implement and optimize existing processes in many countries across the globe, ensuring that these processes comply with all the applicable regulations. It goes without saying that, besides considerations of product quality and purity, system safety is also of utmost important. R. STAHL components have been developed for environments

specific to the pharmaceutical industry such as clean rooms. They satisfy even the most stringent safety and hygiene requirements, and also have ATEX and IECEx

certification for Zones 1 and 2, as well as NEC certification for Class I, Divisions 1 and 2. We have the national certificate PESO on selected products.

What opportunity does the company envisage in manufacturing sector with the Indian Government's emphasis to bring sustainability & efficiency through the launch of 100 smart cities?

Industry 4.0 will be a key differentiator in an organization's success. First movers in driving this revolution are likely to be marching ahead with revenue gains of more than 30% and cost reduction of more than 30% at the same time. The approach includes developing platforms such as PLM and MES to stay closer to the customers. Digital integration with customer by creating closer and far impactful relationships and using data as a tool to sharpen responsiveness and customer services are fundamental levers of the Industry 4.0. Within the

next few years, Industry 4.0 will become a hygiene to compete and is potentially likely to be a barometer for investor funding for not just incubating new businesses but also sustaining existing ones.

EX 4.0 solutions from R. STAHL are catalyzing transformation through highly advanced technological solutions suited to meet all the requirements of the 21st century and enable remote monitoring, remote diagnostics and remote control, as well as big data for optimizing processes and systems. They are not just built to resist external hazardous environmental influences but are most reliable, intelligent and efficient to support the 4th Industrial Revolution led by the Internet.

What are the services offered by the company in lighting segment?

R. STAHL offers a wide range of flame proof lighting solutions such as, general lighting, floodlights, compact lights, hand lamps or emergency lighting systems, tubular lighting, pendant lighting, linear lighting and many more. We manage the entire project lifecycle, from the design stage to the manufacturing stage, to produce bespoke Ex lighting, custom lighting systems and complex emergency

The growing global population has led to an increasing demand for food which has largely contributed to the growth of food and beverage industries. We need a catalyst line here to connect growing FMCG needs and the dust generated in these production units.

lighting systems (central battery units), and offer a comprehensive service in this field. Explosion-protected LED solutions from R. STAHL: Long-life, efficient and innovative. R. STAHL has extensive expertise in lighting design, explosion-proof light fittings and LED technology for hazardous areas and harsh environments. This makes us a well-qualified, flexible partner for creating modern lighting solutions with particularly low energy consumption and minimal maintenance requirements. We offer solutions in the form of sustainable energy and also create value for every ounce of customer investment.

What are the major technological innovations you are bringing to the world market this year?

We are very serious when it comes to innovation and this is palpable in the processes that we have instilled and the results that we have reaped. R. STAHL India has the largest R&D center that is similar to our

headquarters in Germany. Most of our products have a minimum lifetime of 30 years – yes, that’s a minimum! Maintenance is not a concern anymore to the customers. We do not compromise on quality and value to our customers.

A significant launch is the new R. STAHL EXpressure technology that safely dissipates explosion pressure in control boxes, power distribution boards and other enclosures via flow channels in multi-layer stainless steel wire clothes. If explosion pressure increases from 7 bar to 12 bar, it has to be contained in a conventional flameproof enclosure while the maximum inner pressure in an EXpressure enclosure is substantially less than 1 bar! If previously, a wall thickness of 10 to 20 mm was required, EXpressure enclosures can do the same thing with walls that are approximately 3 mm thick. The compact construction design of EXpressure enclosures makes significantly lighter and slimmer solutions possible. These result in savings of approximately 30 to 50 % in weight and 25 % in outer dimensions when compared to conventional switchgear and control gear assemblies

We are also launching this month at Achema 2018, the new slim line series of ISpac isolator system. First in line are switching repeaters, transmitter supply units and digital outputs for controlling solenoid valves. With a width of 12.5 mm, the new dual-channel modules save up to 30% space in the control cabinet. This also means a reduction in installation cost, as less space means a significant increase in signal density.

Also, R. STAHL Camera Systems BU has designed a new, compact full HD camera for visual process surveillance in hazardous areas Zone 1 and 21. Available with 3x and 10x zoom, the surveillance cameras feature state-of-the-art video functions for universal application in the oil and gas industry as well as in the pharmaceutical and chemical industries. It is the most cost effective solution that reduces the burden of financial stress when planning to install powerful video surveillance.

How would you differentiate Indian energy markets as compared to global energy markets?

India stands third among 40 countries in Renewable Energy Country Attractiveness Index survey done by EY, on back of strong focus by the government on promoting sustainable energy. More than 250 global and domestic companies have committed to generate 200 plus GW of solar, wind, mini-hydel and biomass-

based power in India over the next decade. The initiative would entail an investment of about US\$ 310–350 billion. The country has seen 3.44 per cent of total FDI inflows in the power sector in the last 15 years. The Government of India has released its roadmap to achieve 175 GW capacity in renewable energy by 2022, which includes 100 GW of solar power and 60 GW of wind power. The 2026 forecast for India's non-hydro renewable energy capacity has been increased to 155 GW from 130 GW on the back of more than expected solar installation rates and successful wind energy auctions. India could become the world's first country to use LEDs for all lighting needs by 2019, thereby saving Rs 40,000 crore (US\$ 6.23 billion) on an annual basis. Energy market though recorded only a 2.46% contribution to country's GDP in FY17 as against 19.1% in Norway and 5.9% in the US. However, it is for certain that the energy sector will be on an upswing and will hold center stage among the different growth drivers of our economy.

What are your expansion plans in India with the government's 'Make in India' program?

Currently, we do have a state-of-the-art factory at the Indian Headquarters in Chennai, Tamil Nadu. We are further expanding our current capacities to meet the requirements of India, ME & APAC. We are positively driving towards 25% growth this year whilst supporting the make in India campaign.

What is your outlook for 2018-19 fiscal for the power segment?

2018-19 will be an exciting and challenging year for the energy market. The industry is going through a significant transformation. The potential growth levers for the industry also come along with competitive intensity at both market and supply sides in factors such as fuel, logistics, finances and manpower. The country is poised to become the world's first nation to use LEDs for all lighting needs by 2019, thereby saving Rs 40,000 crore (US\$ 6.23 billion) on an annual basis. The government's initiatives such 10 year tax exemption for solar energy projects in order to achieve the country's renewable energy targets of adding 175 GW of renewable energy is a positive stroke to the power segment. R. Stahl with the widest range of offering will continue to be a dominant player in the entire energy sector with increasing customizations and focus to build anti-explosion technologies for tomorrows! 



VISION & COMMITMENT TO EXCELLENCE

We are the India's Leading manufacturer of Cables & Conductors. For over 30 Years, we are continuously expanding our presence in Indian and Overseas market to Electricity Boards, Government and Private Power Utilities, Private Contractors & Various EPC Companies. Our Organizational Philosophy is backed by Product Excellence , Customer delight technological advancements and an environmentally friendly approach.

Manufacturer & Exporters of:

- 66 KV XLPE Power Cables • HT & LT Aerial Bunched Cables
- HT & LT XLPE UG Power Cables • LT PVC Power & Control Cables
- FR/FRLS/LSZH Cables • Airdac, Communication & Concentric Cables
- Solar Power Cables • Bare & Insulated Copper Conductors
- ACSR, AAA, AA, AL59 & HTLS Conductors • Railway Signalling, Power & Quad Cables



Dynamic Cables Ltd.

(A Govt. Recognised Export House) AN ISO 9001:2015 & OHSAS 18001:2007 Certified Company
Registered Office: F-260, Road No.13, V.K.I.Area, Jaipur- 302013, Rajasthan, India
Ph: +91-141-2332388, 2262589, 4042005 | Fax: +91-141-2330182
E-mail: info@dynamiccables.co.in | Website: www.dynamiccables.co.in

— Supporting —



Means of a Lithium-Ion-Battery

The growing use of Li-Ion batteries include but are not limited to smart phones, tablets and more commonly notebooks, radio controlled hobby vehicles, portable vaporizers, UAV and drones. Some cleverly formatted Li-Ion batteries have also been used in wearable electronic devices...



A lithium-ion battery (abbreviated as LIB) is a type of rechargeable battery in which lithium ions move from the negative electrode to the positive electrode during discharge and back when charging. Handy, helpful lithium-ion battery was pioneered at Oxford University in the 1970s by chemist John Goodenough and his colleagues. Their research was published in 1980 and turned into a commercial technology by Sony, who produced the first lithium ion battery in the early 1990s. Since then, Lilon batteries are common in all kinds of devices. Usually, LIBs are significantly lighter than other kinds of rechargeable batteries of similar size. Presently, the growing use of Li-Ion batteries include but are not limited to smart phones, tablets and more commonly notebooks, radio controlled hobby vehicles, portable vaporizers, UAV and drones. Some cleverly formatted Li-Ion batteries have

Picture Credit : www.powerbanksindia.com

also been used in wearable electronic devices. Li-Ion batteries are often compared to Li-Po (lithium polymer) batteries. However, Li-Po batteries aren't commercially available due to their poor room-temperature performance. There have also been some incidents of combustion/explosion in Li-Ion batteries in high-drain applications. The best battery choice really depends on the particular application. Li-Ion has better low-temperature discharge performance, with operating ranges of -20°C to 60°C . Some can suffer from aging, however, even when not in use. Although care must be exercised in sourcing the batteries, Li-Ion is better suited to very high-drain devices.

Inside a Lithium-ion Battery

Unlike the disposable lithium primary battery, a LIB uses intercalated lithium compound instead of metallic lithium as its electrode. As with most batteries Li-ion batteries also have an outer case made of metal. The use of metal is particularly important here, because the battery is pressurized. This metal case has some kind of pressure-sensitive vent hole. If the battery ever gets so hot that it risks exploding from over-pressure, this vent will release the extra pressure. The battery will probably be useless afterwards, so this is something to avoid. The vent is strictly there as a safety measure, so is the Positive Temperature Coefficient (PTC) switch, a device that is supposed to keep the battery from overheating. This metal case holds

a long spiral comprising three thin sheets pressed together: positive electrode, negative electrode and a separator. Inside the case these sheets are submerged in an organic solvent that acts as the electrolyte. Ether is one common solvent. The separator is a very thin sheet of micro-perforated plastic. As the name implies, it separates the positive and negative electrodes while allowing ions to pass through. The positive electrode is made of Lithium Cobalt Oxide, or LiCoO_2 . The negative electrode is made of carbon. When the battery charges, ions of lithium move through the electrolyte from the positive electrode to the negative electrode and attach to the carbon. During discharge, the lithium ions move back to the LiCoO_2 from the carbon. The movement of these lithium ions happens at a fairly high voltage, so each cell produces 3.7 volts. This is much higher than the 1.5 volts typical of a normal AA alkaline cell and helps make lithium-ion batteries more compact in small devices like cell phones. Lithium-ion battery in all shapes and sizes would have the following:

- The lithium-ion cells, either cylindrical batteries that look almost identical to AA cells, or they can be prismatic, which means they are square or rectangular.
- One or more temperature sensors to monitor the battery temperature
- A voltage converter and regulator circuit to maintain safe levels of voltage and current
- A shielded notebook connector that lets power and information flow in and out of the battery

- A voltage tap, which monitors the energy capacity of individual cells in the battery
- A battery charge state monitor, which is a small computer that handles the whole charging process to make sure the batteries charge as quickly and fully as possible. If the battery pack gets too hot during charging or use, the computer will shut down the flow of power to try to cool things down. In case of extremely hot environment this computer may prevent from powering up until things cool off. If the cells ever become completely discharged, the battery pack will shut down because the cells are ruined. It may also keep track of the number of charge/discharge cycles and send out information on how much charge is left in the battery.

Working of a Lithium-ion Battery

Batteries store and release energy by moving electrons from one end of the battery to the other. Then we can use the energy from those moving electrons to do work for us. These two battery "ends" are known as electrodes. One is called the anode and the other is called the cathode. Generally, the anode is made from carbon and the cathode from a chemical compound known as a metal oxide (cobalt oxide, for example). The final battery ingredient is known as the electrolyte, and it sits in between the two electrodes. In the case of lithium-ion batteries, the electrolyte is a salt solution that contains lithium ions—hence the name. When we place the battery

Lithium-ion Battery: Powering a device

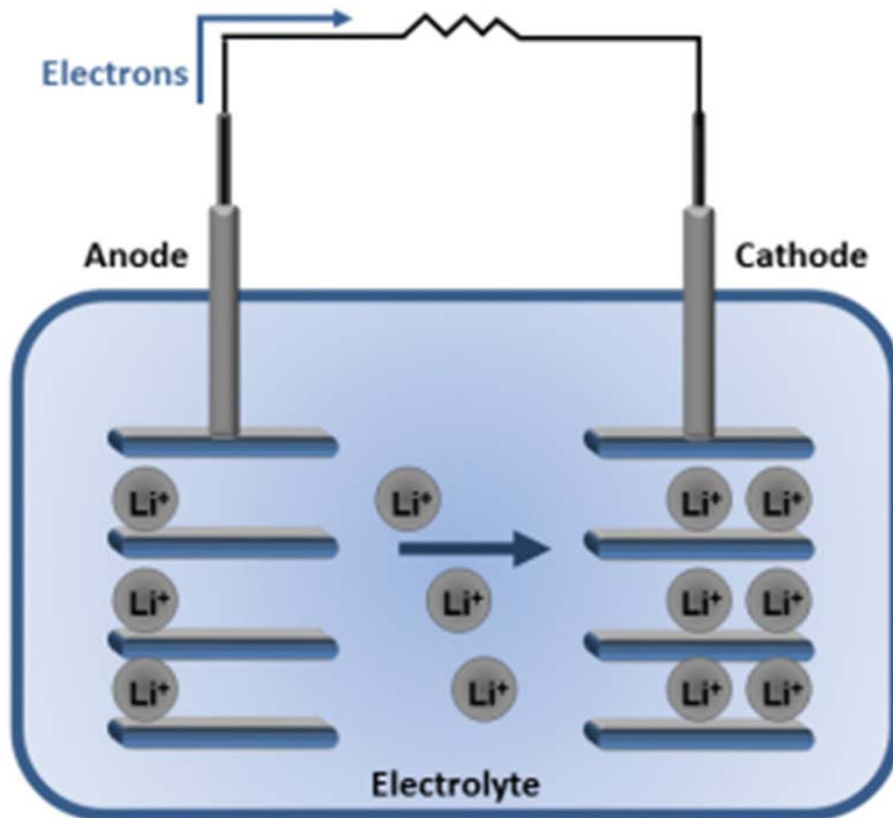

in a device, the positively charged lithium ions are attracted to and move towards the cathode. Once it is bombarded with these ions, the cathode becomes more positively charged than the anode, and this attracts negatively charged electrons. As the electrons start moving toward the cathode, we force them to go through our device and use the energy of the electrons “flowing” toward the cathode to generate power. You can think of this kind of like a water wheel, except instead of water flowing, electrons are flowing. Lithium-ion batteries are great because they are rechargeable. When the battery is connected to a charger, the lithium ions move in the opposite direction as before. As they move from the cathode to the anode, the battery is restored for another use.

Growth & Development of Li-Ion Batteries

Lithium battery technology has taken many years to develop. It offers distinct advantages over other older rechargeable battery technologies such as Nickel cadmium and Nickel Metal Hydride. The idea for lithium ion battery technology was first proposed in the 1970s by M Whittingham who used titanium sulphide and lithium metal as the electrodes for his cell. Work was undertaken at the University of Pennsylvania to enable a graphite electrode to be used with lithium ions in the electrode. This was a major advance, although it was not taken up immediately by other advances in lithium ion technology. However, other techniques associated with charging needed to be solved before a viable cell

could be made. In 1979, J Goodenough demonstrated a rechargeable lithium ion cell using Lithium Cobalt Oxide for the positive electrode and lithium as the negative one. The next stages in producing a workable production cell were to be able to enable recharging action with lithium in graphite which was achieved by in 1979. It then took until 1985 before a rechargeable lithium ion cell was developed that could be manufactured in large scale production quantities. Akira Yoshino used carbonaceous material which would accept lithium ions as one electrode, and lithium cobalt oxide, LiCoO_2 as the other. The use of Lithium Cobalt Oxide was important, because it is stable in air unlike lithium itself, and this made this cell structure more stable chemically and far less dangerous. Lithium-ion batteries are common in home and portable electronics. LIBs are also growing in popularity for military, battery electric vehicle and aerospace applications. Chemistry, performance, cost and safety characteristics vary across LIB types. Handheld electronics mostly use LIBs based on lithium cobalt oxide (LiCoO_2), which offers high energy density, but presents safety risks, especially, when damaged. Lithium iron phosphate (LiFePO_4), lithium ion manganese oxide battery (LiMn_2O_4 , Li_2MnO_3 , or LMO) and lithium nickel manganese cobalt oxide (LiNiMnCoO_2 or NMC) offer lower energy density, but longer lives and less likelihood of explosion. Such batteries are widely used for electric tools, medical equipment,

Nurturing Passion for **ENGINEERING & TECHNOLOGY**



Titan Engineering & Automation Limited (TEAL), is a wholly owned subsidiary of TITAN COMPANY LIMITED. We are in the business of Providing world class Turnkey assembly and testing solutions



We cater to various industry segments like:

- **Transportation**
- **Energy**
- **Electronics**
- **Life sciences**
- **Engineering**
- **Consumer packaged goods (CPG)**

WE OFFER



Linear Transfer Assembly Line



Rotary Assembly Line



Lean Assembly Line



Robotic Assembly Line



Vision Inspection System

Our Capabilities

- **Assembly Technology**
- **Testing & Measurement**
- **Controls & Software**
- **Industry 4.0 Enabled Solutions**

For Enquiries Contact

Head Office

Mr. Hari.E

+91 – 94422 67678

harie@titan.co.in

Northern Region

Mr. Aditya Shandilya

+91 – 96500 91004

aditya@titan.co.in

Southern Region

Mr. Praveen Kumar

+91 – 73977 01444

praveenk1@titan.co.in

Western Region

Mr. Kiran Naik

+91 – 94421 65044

kiran@titan.co.in

Reach us at:

TITAN ENGINEERING & AUTOMATION LIMITED (TEAL),

UNIT 1 :- Automation Solutions, No. 27 & 28, SIPCOT Industrial Complex, Hosur - 635126, Tamil Nadu, India

Tel :- +91- 4344 664 876 / 891 / 840

Email:- infotas@titan.co.in , Website :- www.titanautomation.in

Table 1: Lithium Ion Battery Technologies Summary

Name	Constituents	Major Characteristics	Applications
Lithium Cobalt	LiCoO ₂	High capacity	Cellphones, laptops, cameras
Lithium Manganese Oxide	LiMn ₂ O ₄	Safety, but lower capacity	Power tools, medical, hobbyist
Lithium Iron Phosphate	LiFePO ₄	Safety, but lower capacity	Power tools, medical, hobbyist
Lithium Nickel Manganese Cobalt Oxide	LiNiMnCoO ₂	Safety, but lower capacity	Power tools, medical, hobbyist
Lithium Nickel Cobalt Aluminium Oxide	LiNiCoAlO ₂		Electric vehicles and grid storage
Lithium Titanate	Li ₄ Ti ₅ O ₁₂		Electric vehicles and grid storage

and other roles. Lithium nickel cobalt aluminum oxide (LiNiCoAlO₂ or NCA) and lithium titanate (Li₄Ti₅O₁₂ or LTO) are specialty designs aimed at particular niche roles. The newer lithium-sulfur batteries promise the highest performance-to-weight ratio. Lithium-ion batteries can pose unique safety hazards since they contain a flammable electrolyte and may be kept pressurized.

A brief history of research and technology advances reaching to the present state of art of lithium ion battery is shown in Table 1.

In order to improve the efficiency and decrease the charge time of lithium-ion batteries, many companies and researchers are using nanotechnology to make better battery materials. A lot of research is focused on using nanotechnology to make better electrodes. Using nanomaterials in the electrodes increases their surface area, which provides more places for the lithium ions to make contact. This makes the battery more efficient and also makes it recharge faster. These changes should make electronic devices that use lithium ion batteries lighter and also allow them to go a longer time before recharging. Lithium-ion batteries using nanophosphate for the cathode

material take advantage of the increased surface area provided by nanomaterials. This allows the battery to go through thousands of charges, an estimated two to three times more than other lithium ion batteries, without changes in performance. In addition to the longer life, the nanophosphate batteries are much lighter than other lithium-ion batteries and charged fast.

New Designs

Lithium-air batteries – believed to be able to hold up to five times more energy than the lithium-ion batteries that power our phones, laptops and electric vehicles – have been tantalizing to battery researchers for years but several obstacles have plagued this development. The batteries would work by combining lithium present in the anode with oxygen from the air to produce lithium peroxide on the cathode during the discharge phase. The lithium peroxide would be broken back down into its lithium and oxygen components during the charge phase. Unfortunately, experimental designs of such lithium-air batteries have been unable to operate in a true natural-air environment due to the oxidation of the lithium anode and production of undesirable

byproducts on the cathode that result from lithium ions combining with carbon dioxide and water vapor in the air. These byproducts gum up the cathode, which eventually becomes completely coated and unable to function. These experimental batteries have relied on tanks of pure oxygen – which limits their practicality and poses serious safety risks due to the flammability of oxygen. The research team overcame these challenges by using a unique combination of anode, cathode and electrolyte – the three main components of any battery – to prevent anode oxidation and buildup of battery-killing byproducts on the cathode and allow the battery to operate in a natural-air environment. They coated the lithium anode with a thin layer of lithium carbonate that selectively allows lithium ions from the anode to enter the electrolyte while preventing unwanted compounds from reaching the anode. In a lithium-air battery, the cathode is simply where the air enters the battery. In experimental designs of lithium-air batteries, oxygen, together with all the other gases that make up air, enters the electrolyte through a carbon-based spongy lattice structure. Researchers coated the lattice

ALTANOVA

GROUP

Advanced testing and monitoring solutions



TRANSFORMER

INTEGRATED GLOBAL MONITORING SYSTEM

Our intelligent, integrated monitoring system solutions provide the ultimate protection for your Transformers.

ALTANOVA offers a wide range of sensors and systems to monitor the condition of power transformers, forming them to the unique Global Monitoring™ for transformers.

A combination of PD, Tan-D and DGA provides the best protection available for a highly complex and expensive asset.

At **ALTANOVA**, we ensure that you work towards business growth with enough time to do what you should be doing, while we take care of all your Electrical Assets...



Regional Office: C-33, Ground Floor, Sector-2, Noida-201301, Uttar Pradesh, India
Telephone: +91 120 4543853 / 54 / 4222712; **Fax:** +91 120 4574772
Website: www.altanova-group.com, **Email:** info.asia@altanova-group.com

TECHMP

structure with a molybdenum disulfate catalyst and used a unique hybrid electrolyte made of ionic liquid and dimethyl sulfoxide, a common component of battery electrolytes, that helped facilitate lithium-oxygen reactions, minimize lithium reactions with other elements in the air and boost efficiency of the battery. Researchers have designed a new lithium-air battery that works in a natural-air environment and still functioned after a record-breaking 750 charge/discharge cycles.

Advantages of Lithium-ion Batteries

Lithium-ion batteries (LIBs) are incredibly popular these days. Today, lithium-ion is one of the most successful and safe battery chemistries available. Two billion cells are produced every year. We can find them in laptops, PDAs, cell phones and iPods. They're some of the most energetic rechargeable batteries available. Lithium-ion batteries are popular, because they have a number of important advantages over competing technologies:

Lighter: much lighter than other types of rechargeable batteries of the same size. The electrodes of a lithium-ion battery are made of lightweight lithium and carbon.

High-energy density: Lithium is also a highly reactive element, meaning that a lot of energy can be stored in its atomic bonds. This translates into a very high energy density for lithium-ion batteries. A typical lithium-ion battery can store 150 watt-hours of electricity in 1 kilogram of battery. For a comparison, a NiMH (nickel-metal hydride) battery pack can store

perhaps 100 watt-hours per kilogram, although 60 to 70 watt-hours might be more typical. A lead-acid battery can store only 25 watt-hours per kilogram. Using lead-acid technology, it takes 6 kilograms to store the same amount of energy that a 1 kilogram lithium-ion battery can handle.

Long charge holding: They hold their charge for long and lose only about 5 percent of its charge per month, compared to a 20 percent loss per month for NiMH batteries. Lithium-ion batteries can handle hundreds of charge/discharge cycles.

Self-discharge: One issue with batteries and cells is that they lose their charge over time. This self-discharge can be a major issue. One advantage of lithium ion cells is that their rate of self-discharge is much lower than that of other rechargeable cells such as Ni-Cad and NiMH forms.

Memory effect: They have no memory effect, which means that we do not have to completely discharge them before recharging, as with some other battery chemistries.

Rechargeable: Lithium ion battery is rechargeable makes it more desirable and sustainable.

Variety of types available: There are several types of lithium ion cell available. This advantage of lithium ion batteries can mean that the right technology can be used for the particular application needed. Some forms of lithium ion battery provide a high current density and are ideal for consumer mobile electronic equipment. Others are able to provide much higher current levels and are ideal for power tools and electric vehicles.

Problems with Lithium-ion Batteries

That is not to say that lithium-ion batteries are flawless. They have a few problems as well:

- They start degrading as soon as they leave the factory. They will only last two or three years from the date of manufacture whether we use them or not.
- They are extremely sensitive to high temperatures. Heat causes lithium-ion battery packs to degrade much faster than they normally would.
- If we completely discharge a lithium-ion battery, it is ruined.
- A lithium-ion battery pack must have an on-board computer to manage the battery. This makes them even more expensive than they already are.
- Lithium-ion batteries have the possibility to burst into flames occasionally. Though this is not very common – just two or three battery packs per million have a problem.
- **Protection required:** lithium ion cells and batteries are not as robust as some other rechargeable technologies. They require protection from being over charged and discharged too far. In addition to this, they need to have the current maintained within safe limits. Accordingly one lithium ion battery disadvantage is that they require protection circuitry incorporated to ensure they are kept within their safe operating limits. Fortunately, with modern integrated circuit technology, this can be relatively easily incorporated into the battery or within the equipment if the



SAFETY FIRST



ONLY ECO FRIENDLY
Maintenance Free Earthing System



GI Earthing Electrode

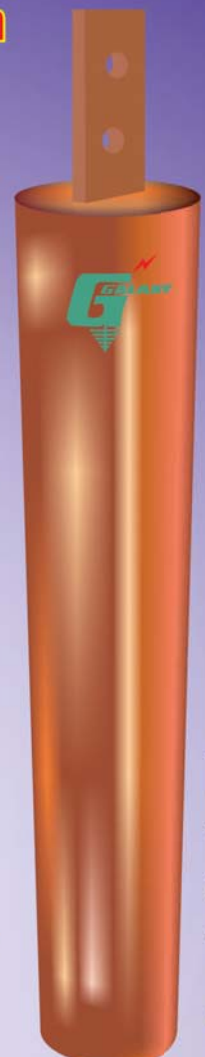

Copper Earthing Electrode

USING ONE 'GALAXY' EARTH ELECTRODE IS EQUIVALENT
TO 5 NOS.OF COPPER BONDED ROD

RANGE OF PRODUCTS



GLOBAL SOLUTION FOR EARTHING (GROUNDING)



GALAXY EARTHING ELECTRODES (P) LTD.

(An ISO 9001:2015 Certified)

Regd.Off: K.M.Complex, 1st Floor, No.23, Jawaharlal Nehru Road, (100 Feet Road) Arumbakkam, Chennai - 600 106. INDIA

Phone: +91-44-23635996, 23635547, Mobile: +91-9940023932, 8939565802 Fax: +91-44-23635550

Email: galaxyearthing@gmail.com, galaxiearthing@yahoo.co.in

Website: www.galaxyearthingelectrode.com

Factory: Ambattur Industrial Estate (S.P.) Chennai - 600 058. INDIA

Power Electronics

battery is not interchangeable.

- **Ageing:** One of the major lithium ion battery disadvantages for consumer electronics is that lithium ion batteries suffer from ageing. Not only is this time or calendar dependent, but it is also dependent upon the number of charge discharge cycles that the battery has undergone. When a typical consumer lithium cobalt oxide, LCO battery or cell needs to be stored it should be partially charged - around 40% to 50% and kept in a cool storage area. Storage under these conditions will help increase the life.
- **Transportation:** Another disadvantage of lithium ion batteries is that there can be certain restrictions placed on their transportation, especially by air. Although the batteries that could be taken in aircraft carry-on luggage are unlikely to be affected, care should be taken not to carry any more lithium ion batteries than are needed. Any carried separately must be protected against short circuits by protective covers, etc.
- **Cost:** A major lithium ion battery disadvantage is their cost. Typically they are around 40% more costly to manufacture than Nickel cadmium cells. This is a major factor when considering their use in mass produced consumer items

where any additional costs are a major issue.

- **Immature technology:** Lithium ion battery technology is a developing area. This can be a disadvantage in terms of the fact that the technology does not remain constant. However as new lithium ion technologies are being developed all the time, it can also be an advantage as better solutions are coming available.

Guidelines to Use Li-ion Batteries

Lithium-ion batteries are expensive, so to make it last longer, here are some things to keep in mind:

- Avoid heat, which degrades the batteries
- Li-ion batteries should be bought only when needed, because the aging process begins as soon as the battery is manufactured. If a Li-ion battery is not to be used for an extended period of time it should ideally be brought to a charge level of between about 40% and 60% of full charge.
- Li-ion batteries should be kept cool. By keeping them cool, possibly in a refrigerator, the ageing process becomes slower. As a result, Li-ion batteries should not be kept in cars on sunny days as the temperatures rise significantly
- Li-ion batteries should never be depleted to below their

minimum voltage, 2.4 V to 3.0 V per cell

- Li-ion batteries should not be exposed to very low temperatures - most lithium-ion battery electrolytes freeze at approximately 40°C. This may preclude them from some applications where equipment needs powering in extremes of temperature
- Lithium ion chemistry prefers partial discharge to deep discharge, so it's best to avoid taking the battery all the way down to zero. Since lithium-ion chemistry does not have a "memory", we do not harm the battery pack with a partial discharge. If the voltage of a lithium-ion cell drops below a certain level, it's ruined
- Lithium-ion batteries should be charged before the battery is completely discharged
- Lithium-ion batteries should not be frequently fully discharged and recharged ("deep-cycled") like Ni-Cd batteries. However this may be needed occasionally to recalibrate any associated "fuel gauge" circuitry used to monitor the state of charge, control charging, etc. 



Dr S S Verma

Department of
Physics, S.L.I.E.T.,
Longowal, Punjab

Become the new face of
growing technology

Advertise in **Electrical India**

Contact **Yasmeen** at

+91 22 27777 7196 / +91 9867914216

Print + Digital / eNewsletter / Website

THE IMPOSSIBLE IS OFTEN

THE TASKS UNTRIED

BESIDES BI-MONTHLY MAGAZINE TAKE ADVANTAGE OF THE DIGITAL TECHNOLOGY & READ **LIGHTING INDIA** MAGAZINE ONLINE, AS WELL AS FORTNIGHTLY E-NEWSLETTER ON YOUR PC, TABLET OR LAPTOP.

To **Subscribe** & Be Updated Please fill the form (P.T.O.)

PLEASE TURN BACK FOR THE SUBSCRIPTION FORM.

Come Join us in endeavour to bring the lighting industry to you, on the most read media platform of **LIGHTING INDIA**.

"WE TRAVEL AROUND THE WORLD TO GET NEWS, PRODUCTS & PROJECTS FOR YOU, SO THAT YOU CAN KEEP PACE WITH THE REST OF THE WORLD "



CHARY PUBLICATIONS PVT LTD.

905-906, THE CORPORATE PARK PLOT NO. 14 & 15, SECTOR - 18, OPP. SANPADA RAILWAY STATION, VASHI, NAVI MUMBAI - 400 703. FOR SUBSCRIPTION PLEASE CONTACT PRIYANKA ON 022-2777182/8652142057 OR EMAIL ON sub@charypublications.in

Read and advertise in India's foremost magazine on LIGHTING INDUSTRY.

SUBSCRIBE

Lighting India

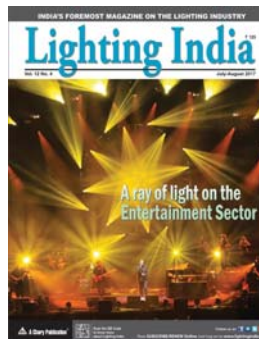

Subscription Offers

Sub. Period	No. of Issues	Subscription Type					
		Print		Digital		Print+Digital	
		Actual Rate	You Pay	Actual Rate	You Pay	Actual Rate	You Pay
1 Year	6	750.00		750.00		1500.00	1125.00
2 Years	12	1500.00	1350.00	1500.00	1350.00	3000.00	2025.00
3 Years	18	2250.00	2000.00	2250.00	2000.00	4500.00	3000.00
5 Years	30	3750.00	3000.00	3750.00	3000.00	7500.00	4500.00
E-Newsletter							
1 Year	24	N. A.		365.00		N.A	

MAGAZINE WILL BE SENT BY REGISTER PARCEL --Rs.220/YEAR

KINDLY ADD POSTAGE CHARGES IN SUBSCRIPTION AMOUNT

Subscription / Renewal Form

To,
The Subscription in-charge
LIGHTING INDIA
Email: sub@charypublications.in

Are you a Subscriber,
Please submit your Subscription no:

Yes, I would like to Subscribe/renew Lighting India / LI e-Newsletter for _____ years at ₹_____.

PAYMENT DETAILS :

Cheque / DD No. _____ Dated _____ Drawn on Bank _____
_____ Branch _____ in favour of Chary Publications Pvt. Ltd.

Bank details for NEFT / RTGS / IMPS : Account Name: Chary Publications Pvt. Ltd.

Bank Name: Bank of India Branch: Chembur, Mumbai - 400 071 Account Type: Current Account

IFSC Code: BKID0000009 Bank A/C Number: 000920110000322 SWIFT CODE :BKIDINBBCHM

Name: _____

Company: _____ Designation: _____

Address: _____

_____ City: _____ Pin: _____

Telephone: _____ Mobile: _____

Email: _____

Signature: _____

Stamp

 **Chary Publications Pvt. Ltd.**

905-906, The Corporate Park, Plot No. 14 & 15, Sector 18, Opp. Sanpada Railway Station, Vashi, Navi Mumbai - 400 703.

Phones: +91 22 27777 170 / 171 • Email: sub@charypublications.in • Contact : Priyanka Alugade • +91 22 27777182 / +91 8652142057

REDUCE FAILURE RATE OF ELECTRICAL EQUIPMENTS

&
SAVE ENERGY

by installing

**JINDAL'S INDUSTRIAL ROBOT
AUTOMATIC VOLTAGE CONTROLLER**

A breakthrough in energy conservation

**5 Years
Guarantee**



CAPACITY :
30 TO 100 KVA



CAPACITY :
150 TO 3000 KVA



AN ISO 9001:2008
CERTIFIED COMPANY

GENERAL TREND OF VOLTAGE DURING DAY TIME



NOTE: We can provide you the computerized printout of voltage variation at your premises by installing the Data Loggers



JINDAL ELECTRIC & MACHINERY CORPORATION

C-57, Focal Point, Ludhiana (India) Tel : +91-161-2670250, 2676890, 2676968 Mobile : 98140 84948, 98142 28100
E-mail : jemc@jindalelectric.com Website : www.jindalelectric.com



150W Sine-wave Inverter

Input:

- Solar Panel Voltage : Max 24 V DC, 60 W
- Auxiliary Supply Input : 18 V - 24 V DC

Battery:

- 12 V DC Lead-Acid Max 40 Ah
- Charging Current: 0.1 to 6 A

Environmental:

- 45 Degrees Ambient with upto 95% non-condensing relative humidity

Features:

- MPPT Algorithm for Solar Panel Power Conversions
- 32 Bit Micro-processor Based Design for Reliable Operation
- Input Over Voltage, Output Over Load Protection
- Precise Three Stage Battery Charging for Extended Battery Life
- Battery Over Charge and Deep Discharge Protection
- Easy Fault Diagnosis with Status LEDs
- Automatic Internal Cooling for Extended Operation in Extreme Environments
- Pure Sine Wave Output For Trouble Free Operation of Connected Appliances
- Output Short Circuit Protection
- Battery Low Indication, Battery Full Charge Indications
- Low Power Consumption

Output:

- 230 V AC, 50 Hz, ±5%
- Rated Wattage: 150 W Internally Limited
- 12V DC Output

Ganesh Electronics & Electricals

A/101, Shree Labh Apt. Tulsī Bag Compound, TPS-III, Opp. Bhatia Hall, L.T. Road, Boriwali (W), Mumbai 400 092
email: swarnlite@gmail.com ajubir1963@gmail.com
Phone: 022- 65731411 M: 98690 20685
www.swarnlite.com

Contact:

Mumbai : Ajit 98690 20685
Kolhapur : Nishant 77989 49333
Sangli : Nitin 86001 04108

GSTN: 27AAOFG6152B1ZH

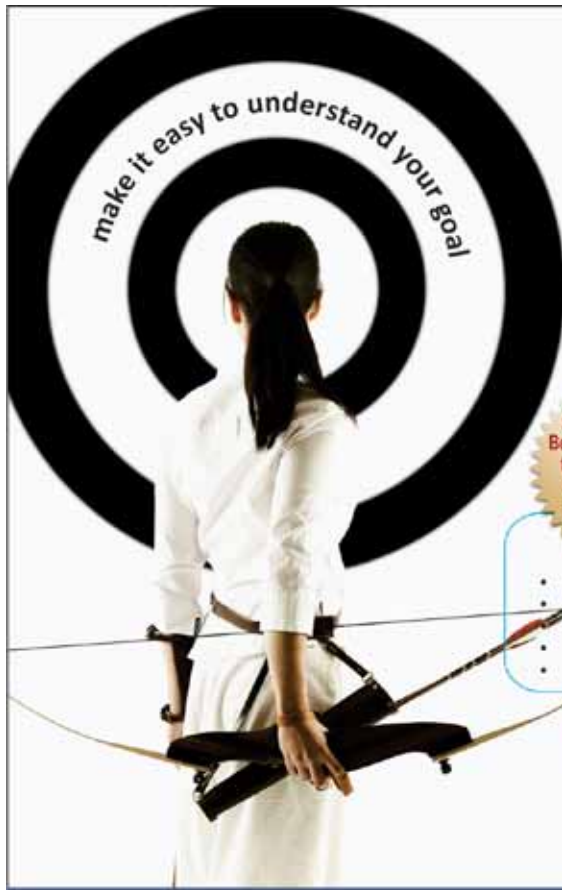

Awarded as the Best IoT Start up of the Year 2018 in AEONIAN 2018 supported by NASSCOM

- Voltage Line-to-Line - VLL(Avg), VRY, VYB, VBR
- Voltage Line-to-Neutral - VLN(Avg), VRN, VYN, VBN
- Amps - I-Avg, IR, IY, IB
- Energy - kWh
- Frequency - Hz

- Power Factor- PF-Avg, PF-R, PF-Y, PF-B.
- Active Power - kW-Total, kW-R, kW-Y, kW-B.
- We are 1st Indian Manufacture to offer Phase Wise Energy Parameters in the Meter kWh-R kW-Y, kWh-B.



Innovation is Crafted and Manufactured in India by
VENLITE ENERGY LIMITED

No. 92, 2nd Main, 6 Cross, Maruti Nagar, Yelahanka, Bangalore - 560064, Karnataka, India.
Tel: +91 80 28571464 • Mobile / What's app: +91 9880238196 / +91 9738389174
Email: venlitelimited@gmail.com • Website: www.venliteenergy.co.in

Branches: Surat; Ahmedabad; Raipur; Gurugram

"Impossible is nothing"

Power Distribution Systems in India

Programs are simultaneously working on many fronts to ensure technical up-gradation of distribution network, to ensure stability of power supply to consumers. However, new challenges need to be addressed in the context of ongoing dynamic global restructuring of energy industries with local context....



Power distribution is the crucial link and the weakest in the electricity supply chain. It assumes great significance as this segment has a direct impact on the sector's commercial viability, and ultimately on the consumers who pay for power services. The sector has been plagued by high distribution losses coupled with theft of electricity, low metering levels and poor financial health of utilities with low cost recovery. Due to this, the distribution companies

have not been able to undertake corresponding investments in infrastructure augmentation.

The sector has started receiving greater attention and investment with the restructuring of the state electricity boards. Several new initiatives have been introduced to reduce aggregate technical and commercial (AT&C) losses along with a definitive regulatory framework. Electricity Act 2003, National Electricity Policy 2005 and National Tariff Policy 2006 are important regulations governing the sector today with an aim to bring competition in the sector and improve the services to the end consumers.

The GoI has also made heavy investments in the distribution sector through the RGGVY and APDRP during the Tenth Plan and has continued to extend the same in the Eleventh Plan as well. The aim of these programs is to provide access of electricity to all and bring down the AT&C losses to a level of around 15% across the country. The various policies and regulations introduced by the government are set to increase competition and bring about commercial viability. Participation of private players into the distribution sector has also been encouraged through various models.

The distribution segment continues to carry electricity from the point where transmission leaves off, that is, at the 66/33 kV level. The standard voltages on the distribution side are, therefore, 66 kV, 33 kV, 22 kV, 11 kV and 0.4kV/o.230 kV, besides 6.6 kV, 3.3 kV and 2.2 kV. Depending upon the quantum of power and the distance involved, lines of appropriate voltages are laid. The main distribution equipment comprises HT and LT lines, transformers, substations, switchgears, capacitors, conductors and meters. HT lines supply electricity to industrial consumers while LT lines carry it to residential and commercial consumers. Several performance indicators deciding the power distribution are discussed in this article.

I. Main factors

Following are the main factors in deciding the Indian power distribution sector.

Continued Demand for Power: The Integrated Energy Policy predicts that in order to eradicate poverty, the country's economic growth needs to be at least 8 per cent annually until 2032 and in that time frame, the power capacity needs to rise to as high as around 800 GW.

Distribution Reforms: Unbundling of the vertically integrated SEBs into functional entities is a key requirement of the EA 2003. While most of the States have unbundled their utilities, the real benefit of unbundling can be derived only through bringing in best practices and professional management through PPP models. Given the political sensitivity and issues on valuation of assets on transfer together with employee reservations, states are looking at the Distribution Franchisee as a middle path for securing efficiencies while addressing the above political/social issues. However, in the long run, privatization seems to be a sustainable solution.

Supply Codes and Performance Standards: Supply Code lays down standards and procedures for recovery of electricity charges, billing cycles, disconnections, and restoration of service and metering among other things. To protect consumer interests, the EA 2003 requires the SERCs to specify standards of performance for distribution licensees. The commissions also have to specify the penalty and



PIONEER IN SILICONE RUBBER PRODUCTS IN INDIA

Our Product Range Includes Silicone Transparent Platinum Cured Tubings

- Silicone rubber tubes (ITI Approved)
- Transparent tubings
- Silicone connector
- Industrial tapes
- LED Gaskets
- Nozzle
- Silicone caps
- Silicone washers
- Inflatable gaskets
- Cords
- Strips
- Squares
- Profile
- Sections
- Gaskets
- Cables
- O rings
- Oil seals
- Sponges
- Sheets
- Autoclave Gaskets
- Corona Treater Sleeves
- Braided Hoses
- Viton Rubber

• Also available as per drawings / specifications.

SEVITSIL SOLUTIONS IN SILICONE

SURESH ENTERPRISES
AN ISO 9001:2015 CERTIFIED

C1/55, GIDC Phase-2, Dediyanan, Mehsana-384002, Guj, INDIA.
Phone: +91-2762-224814 / 224240 / 224239
Sales Head: +91-97277 38001 | Sales Dep.: +91-99250 28109
Email: info@sevitsil.com, sevitsil@gmail.com

compensation to be paid by the licensees to the affected parties if the former fails to meet the standards. Both supply codes and standards of performance help in improving efficiency in power distribution operations and consumer service.

Growing Consumer Awareness: For both SEBs and private companies, consumer interest is becoming a high priority. Connections are far easier to come by, bill payments are being streamlined, and complaints are addressed more promptly and effectively. Call centers have been set up to address supply and billing complaints. It has put in place a SMS based-fault management system whereby complaints are addressed through SMS. This has resulted in increased customer satisfaction across all segments, especially, among urban domestic consumers, thereby, improving the customer's willingness to pay for better services. A virtuous cycle of better customer satisfaction resulting in more revenues for the discoms, who in turn are investing in better services, seems to be finally coming into play.

Focus on IT: All the discoms are adopting IT systems and practices to improve operations and customer service. SCADA is being used for better management of distribution networks. Spot billing, call centers, remote meter reading, automated billing, and energy accounting are some of the IT mechanisms being incorporated. Advanced technologies are being deployed particularly, in billing, fault reporting, remote metering and substation operations,

enterprise solutions involving employees and commerce, consumer servicing through the internet and telephones, and MIS. Energy auditing and accounting are also being taken up assiduously.

Move towards DSM: Realising the benefits of introducing DSM measures in reducing overall electricity demand, several state regulators are encouraging DSMs in their states. Many SERCs have introduced time-of-day with differential tariffs for usage in different times, particularly, for HT consumers. Discoms and regulators are also encouraging the use of energy efficient devices, including efficient pumpsets in agriculture, and efficient lighting and appliances. Farmers are being encouraged to use electricity in non-peak hours. They are also encouraging the use of energy efficient devices, including efficient pumpsets in agriculture, and efficient lighting and appliances.

Environmental and Social Pressures: As a result of increasing environmental pressures, both local and global, the country's power mix is increasingly becoming green. Since power from renewable energy is intermittent, these require a well interconnected grid with adequate spinning reserves and transfer capabilities. Further, as per policy objectives, discoms have to procure a certain percentage of their power requirement through renewable

Tariff Rationalization: The tariff rationalisation will result in commercial viability of the discoms and hence lead to corresponding investments in related infrastructure. With tariff

rationalisation, the HT consumer, who currently bears the burden of higher tariffs, will increasingly find it competitive to buy power from the grid rather than through captive generation. This will further help the discoms in improving their consumer mix, and hence their financials. The consumers below BPL, who consume a small quantity of electricity, shall continue to receive special support through cross-subsidised tariffs.

Improving Grid Standards: The regulatory mechanisms of the availability-based tariff (ABT) and unscheduled interchange (UI) have created a solid base for maintaining grid standards. These should improve further with the newly notified draft for the amendment of the Indian Electricity Grid Code by the Central Electricity Regulatory Commission (CERC). Thus, the utilities will have to focus on demand forecasting, and predict their long-term requirement of power in order to benefit from the ABT regime.

Accelerated Power Development Reforms Program: The scheme was launched in 2002-03 as Additional Central Assistance to the States for strengthening and up-gradation of sub-Transmission and Distribution systems. 50% incentives were given to SEBs / Utilities to reduce their financial losses for actual cash loss reduction.

Key Parameters of Implementation

Other key parameters of implementation to be addressed in order to increase the performance of distribution sectors are as follows:

- AT&C Losses High:** AT&C losses are coming down only in the case of a few reforming. Utilities/SEBs while the national average continues to remain high. There are several pockets of excellence but overall state-wide reduction in AT&C loss remains and a consistent downward trend is not yet visible. Power theft is rampant in some of these states and this has resulted in high non-technical losses. Other causes include faulty meters and unmetered supply. Greater influx of professional services within the limitations of state owned discoms would go a long way in improving system wide AT&C losses.
- Economic Recovery:** Of the total electricity generated, less than 50 per cent is paid for. Electricity is stolen or not billed or electricity bills are not paid at all or not paid on time. The anti-theft legislation passed by the Parliament in June 2007 provides a more stringent framework to check electricity theft and non-payment of bills.
- Tariffs Continue to Suffer:** Most of the problems arise from incorrect pricing of power whereby there are large cross subsidies built into tariff structures which provide incorrect economic signals to the consumers. Populist policies such as free power have proved to be a big dampener with the state governments unwilling or unable to compensate the discoms for the additional costs they have to bear as a result of these measures. Not only do these populist measures put an additional financial burden on the discoms but they also lead to wastage of power by the farmers.
- Investment in Infrastructure:** Investment in the distribution sector has not kept pace with investment in generation, which has led to high T&D losses, poor networks, and delays in projects. Due to distribution network constraints, power cannot be fully transported from surplus to deficit areas, and open access transactions cannot be effectively facilitated.
- Open Access in Nascent Stages:** According to the mandate of the EA2003, open access in transmission was operationalised with immediate effect, and that in distribution was to be implemented in phases. All the SERCs have passed final regulations for implementation of open access in distribution in phases; however, the actual implementation of



ELECTRICAL MEASURING INSTRUMENTS

- PQ ANALYSER - NEW
- SMART ENERGY METERS - NEW
- MIQEN & MISMART SOFTWARE
- SUPERVISION RELAY - NEW
- MEASURING TRANSDUCERS
- UNIVERSAL MEASURING DEVICES
- ANALOGUE INSTRUMENTS
- PORTABLE MULTIMETERS
- SYNCHRONIZATION METERS

iMC784 - ADVANCED POWER QUALITY ANALYZER

CLASS A ACCURACY CERTIFIED BY IEC 61000-4-30 Ed.3

- EN 50160 POWER QUALITY EVALUATION
- AUTOMATIC PQ REPORT GENERATION
- DISTURBANCE, TREND & PQ EVENT RECORDING
- WAVEFORM RECORDER WITH PROGRAMMABLE SAMPLING TIME (max. 625 samples/cycle)
- STANDARDIZED PQDIF AND CONTRADE FORMAT SUPPORT
- SUPPORT FOR MODBUS, DNP3, FTP AND IEC 61850 Ed.2 COMMUNICATION PROTOCOLS (IEC 61850 upgradable)



MIQEN - INSTRUMENT DATA MANAGEMENT SOFTWARE



POWERFUL STUDIO FOR SETTINGS AND MEASUREMENT ANALYSIS OF ALL ISKRA DEVICES

MEASURING CENTRES: MC760-NETWORK ANALYZER / MC750-NETWORK RECORDER / MC740, MC330 - MULTIMETERS



- GRAPHICAL LCD IN HOUSING 96X96 mm (MC 7XX AND MC 3XX)
- OVER 70 ELECTRICAL PARAMETERS MEASUREMENTS
- COMMUNICATION OPTIONS: MODBUS RS232/RS485, ETHERNET TCP/IP, PROFIBUS.
- ACCURACY: 0.5 OR 0.2
- OPTION OF ADDITIONAL COMMUNICATION RS232 OR RS485
- MANY OPTIONS FOR INPUT AND OUTPUT MODULES (ANALOGUE OUTPUT, ANALOGUE INPUT, PULSE OUTPUT, RELAY (ALARM) OUTPUT, DIGITAL INPUT, PULSE INPUT, TARIFF INPUT, WATCHDOG INPUT)

ISKRA RELIABILITY

- 70 YEARS OF EXPERIENCE IN THE FIELD OF ELECTRICAL MEASURING
- 100% MADE IN SLOVENIA - COUNTRY IN EUROPEAN UNION
- OWN DEVELOPMENT AND PRODUCTION OF PRODUCTS; SOFTWARE AND HARDWARE
- ISO 9001:2015 / ISO 14001:2015
- MID / ATEX / BUREAU VERITAS CERTIFIED PRODUCTS
- WORLDWIDE PRESENCE IN MORE THAN 80 COUNTRIES
- HIGH FLEXIBILITY AND CUSTOMER ORIENTATION



Stegnje 21, SI-1000 Ljubljana, Slovenia
+386 1 513 1000 • info@iskra.eu
www.iskra.eu



Unit-II, No. 15, 2nd Floor, 7th Cross, 5th Main,
Ganganagar, BANGALORE - 560032, INDIA.
+91-80-4128 4004 • info@avrelectronics.com
www.avrelectronics.com

open access is still very nascent. Until the issues in open access are resolved, the intent of competition in the retail segment shall never materialize.

Role of Information Technology & Automation

A number of utilities have now started focusing on IT based applications to bring about efficiency in distribution. Moreover, the Restructured APDRP encourages IT enabled applications and automation for reduction of energy losses as well as energy accounting and auditing. Some of the automation and IT enablement in the Power Distribution Sector and their role in improving the commercial viability and service standards are:

- **Customer indexing and GIS based Database:** Consumer indexing based on GIS applications needs to be given priority in the Eleventh Plan to enable the respective utilities to increase their customer coverage, regularize unregistered or unauthorized connections, conduct audits at the feeder level by comparison of energy sent out on a 11kV feeder with total energy meter readings of all HT/LT customers in that particular feeder.
- **Energy Accounting and Auditing:** A robust Energy Accounting and Auditing framework shall help the utilities in prioritization of loss reduction measures and bringing about aggressive reduction in loss levels.
- **Reliability Monitoring of Power Distribution Systems:** There are a number of reliability

indices which measure the outage in terms of, consumer hours and number of consumer interruptions etc. Reliability monitoring will become more fruitful once 'Consumer Indexing' is completed and will provide a direct index for customer satisfaction.

Supervisory Control and Data Acquisition (SCADA)

A well planned and implemented SCADA system not only helps utilities deliver power reliably and safely to their customers but it also helps to lower the costs and achieve higher customer satisfaction and retention.

- **Distribution and Grid Station Automation:** Distribution automation (DA) optimizes a utility's operations and directly improves the reliability of their distribution power system. Adding targeted distribution automation capabilities can be economical when they are an extension of your existing SCADA investments and the communication infrastructure. The success or failure of an automation program hinges on proper selection of equipment and communications to seamlessly integrate data into the utility control room. The key is to choose equipment that leverages your current assets wherever possible. With the latest in high speed communication technology, there has never been a better time for utilities to extend their automation beyond the substation. Substation automation is a rapidly increasing area of interest and

benefit to utilities. Substation automation goes beyond traditional SCADA to provide added capability and information that can further improve operations and maintenance, increase system and staff efficiencies, and leverage and defer major capital investments.

- **Outage Management Systems:** An Outage Management System (OMS) provides the capability to efficiently identify and resolve outages and to generate and report valuable historical information. It also helps the utility inform the customer of the outage situation and restoration status. An OMS typically works in conjunction with a GIS, the utility's CIS, and automated call handling systems, such as an Interactive Voice Response (IVR) system.
- **Distribution Network Planning:** Inadequate network planning is one of the reasons for haphazard and scientific development of the distribution system. The utility should move to proper distribution network planning both for demand forecasting on a medium and long term basis, and for determining the need for system expansion and improvement to meet load growth. This will help in reducing the short term power purchase costs, particularly as short term prices have been high in the near future. Utilities should prepare a perspective network plan for a 10 year period, and this should become

part of the conditionality's for sanction of grants under various programs.

- Automated Meter Reading/Advanced Metering Infrastructure:** Another area gaining prominence is the Automated Meter Reading of high revenue consumers which help the utilities protect their revenues and keep a continuous track of any anomalies at the consumer premises through a remote location. GPRS, GSM and CDMA are being used as the communication medium for these technologies. Advanced metering infrastructure (AMI) is defined as the communications hardware and software, and associated system and data management software that creates a network between advanced meters and utility business systems, and which allows collection and distribution of information to customers and other parties such as competitive retail providers, in addition to providing it to the utility itself. AMI is the wave of the future in distribution sector as more and more focus is laid on demand side management.
- Prepaid Metering:** Pre-paid meters enable efficient use of power for agricultural use and also eliminate adverse impact on the water table due to excessive exploitation of ground water. Though it involves huge capital costs, the gains from the system can offset such costs in the long run. It is expected that large scale use will bring down the

cost of the technologies. Further, prepaid metering can act as an effective tool against defaulters and those found involved in dishonest abstraction of energy. Further, these meters find a prominent use in Govt. accommodations.

- HVDS Systems:** The advantages of HVDS systems apart from reducing theft, it improves the quality of power significantly and thereby improves customer satisfaction. HVDS systems should be given a special focus to get immediate results in loss reduction. The investment on conversions from conventional systems to HVDS is recovered by way of loss reduction within a period of 3 to 5 years in most cases.
- Enterprise Resource Planning:** Employing an enterprise asset management solution will help utilities free work management from tedious and manual data entry and streamline new service initiation through improved dispatch, scheduling and tracking. The utilities can also improve management and tracking of capital invested and reduce spares inventory.
- Smart Grid:** A smart grid delivers electricity from suppliers to consumers using two-way digital technology to control appliances at consumers' homes to save energy, reduce cost and increase reliability and transparency. Such a modernized electricity network is being promoted by many governments as a way of addressing energy

independence, global warming and emergency resilience issues. Smart meters may be part of a smart grid, but alone do not constitute a smart grid. A smart grid includes an intelligent monitoring system that keeps track of all electricity flowing in the system. When power is least expensive a smart grid could turn on selected home appliances such as washing machines or factory processes that can run at arbitrary hours. At peak times it could turn off selected appliances to reduce demand. Smart Grid can be seen as the convergence of three.

Power distribution is regularly monitored, complex system requiring attention. All the stakeholders of distribution viz, Government of India, State Distribution companies, Industries, R&D institutes, practicing engineers and academicians are striving hard in this direction to meet the increasing demands. Programs are simultaneously working on many fronts to ensure technical up-gradation of distribution network, to ensure stability of power supply to consumers. However, new challenges need to be addressed in the context of ongoing dynamic global restructuring of energy industries with local context. 



Dr G D Kamalapur

Professor,
SDM College of
Engineering and
Technology, Dharwad

We are a true leader in power quality solutions



EPCOS, a TDK Group Company, develops, manufactures and markets electronic components and systems, focusing on fast-growing leading-edge technology markets, which include automotive electronics, industrial electronics and consumer electronics as well as information and communications technology.

“We have played a leading role in energy efficiency in terms of compensation of reactive power because we are the leading manufacturer of power factor correction capacitors,” says **N Balakrishnan, Managing Director, EPCOS India Private Limited** in an interaction with Electrical India.

Kindly take us through the journey of the company in India.

The main share of TDK's current electronic components business in India was started decades ago under Siemens Ltd, India, which served as the sales arm of Siemens Matsushita. The company changed to EPCOS India Private Limited when EPCOS AG evolved from Siemens Matsushita in 1999. In 2008, EPCOS AG was

acquired by TDK Corporation and since then the company has grown to be a leading player in this field. Starting from a small factory with three winding machines, our first-year billing was close to Rs 2 crore. Today, we boast of 100 winding machines, state-of-the-art manufacturing facilities with the widest range of products. We look forward to generating business worth Rs 1000 crore in the next year. More than 50

percent of the products manufactured in India are exported across the globe. We are proud of the fact that we are the only manufacturer producing the entire gamut of film capacitors under one roof.

How do you envisage the growth of the company in Indian markets as compared to the European and Japanese counterparts?

India is a very fast growing market, whereas Japan and Germany are more mature markets. As export-oriented countries, they are known for their global presence. So, they definitely would be able to transact business from Europe and Japan to the other countries. TDK in India is well-positioned for further growth here, as we have manufacturing facilities located right in India, which is an advantage compared to other Japanese and European companies.

What are the application sectors for your products?

What kind of technological innovations would you like to incorporate in your products to

make them more energy efficient and sustainable?

We have a prominent presence in the capacitors market, particularly, film capacitors that are very mature products. The capacitors we manufacture have applications in the electronics industry like automotive, industrial and information and communications technology. The AC capacitors that we manufacture are used in all kinds of motors, pumps, and home appliances like refrigerators, washing machines, dishwashers, and air conditioners. The power factor correction (PFC) capacitors that we manufacture in India are useful in all kinds of power networks, be it in an industrial network or a transmission distribution network.

Our capacitors enhance the power factor by compensating the reactive power and bringing the power factor closer to unity, thus considerably increasing the overall energy efficiency of the power networks. Utilities will penalise customers if their power factor is not close to unity. For this reason, our capacitors are in demand. To mitigate harmonics, we offer filters consisting of capacitors combined with reactors. The next level is PFC systems with capacitors and reactors that can switch in real-time.

In addition to PFC capacitors, we also have introduced our PQSine™ series of active harmonic filters to

address the problem of harmonics. Another new product is PQvar™ static var generator (SVG). Basically, it provides real-time compensation to ensure that you have continuous unity power factor even if you have a varying low load. This you cannot achieve with the existing compensation systems because at some point – with some variation in the load – the power factor could either drop or rise and you will have to make some adjustments. But this won't happen with an SVG. So, it ensures that the power factor is unity at all times. That is how we are progressing. We have played a leading role in energy efficiency in terms of compensation of reactive power because according to our research we are a global market leader for PFC capacitors. And in India we have the largest market

India is a very fast growing market, whereas Japan and Germany are more mature markets. As export-oriented countries, they are known for their global presence.

share of around one third. Based on this and our growing portfolio, I can confidently say that we are a true leader in power quality solutions.

Do you have research and development unit in India?

Our Research and Development is headquartered in Europe and an extended arm is present here in India. We have a full-fledged R&D department for all capacitors.

Do you have the applications in electric vehicle charging stations?

The capacitors, we produce, are applicable in charging stations. We have geared up to supply components to hybrid and electric vehicles. We are also preparing for a future which has to yet become a reality in India i.e. autonomous driving, driverless cars, etc.

The Government has plans of generation of 175 giga watts of renewable energy. So what kind of opportunities do you envisage for your company?

I think solar energy is gaining momentum as 100 GW of solar energy generation has been planned. In solar generation, our involvement will be in electronic components used in solar inverters, and we already have business ventures with major solar inverters players, to whom we supply the essential electronic components.

Glimpse of Energy Meters

Energy meter system designed to meet your specific requirements. These meters measure the instantaneous voltage and currents, calculate its product and gives instantaneous power. This article gives a glimpse of types of energy meters, its advantages, disadvantages and applications...

Electric meter or energy meter is a device that measures the amount of electrical energy consumed. The most common unit of measurement on the electricity measurement is the kilowatt hour [kWh], which is equal to the amount of energy used by a load of one kilowatt hour over a period of one hour. Energy meter system designed to meet your specific requirements. These meters measure the instantaneous voltage and currents, calculate its product and gives instantaneous power. Each customer has different energy monitoring needs and depending on those we can supply electrical energy metering equipment, gas, water or electrical consumption meters.

Electric utilities use electric meters installed at customer's premises for billing purpose. They are typically calibrated in billing units, the most common one being in kilowatt hour (kWh). They are usually read once each billing period.

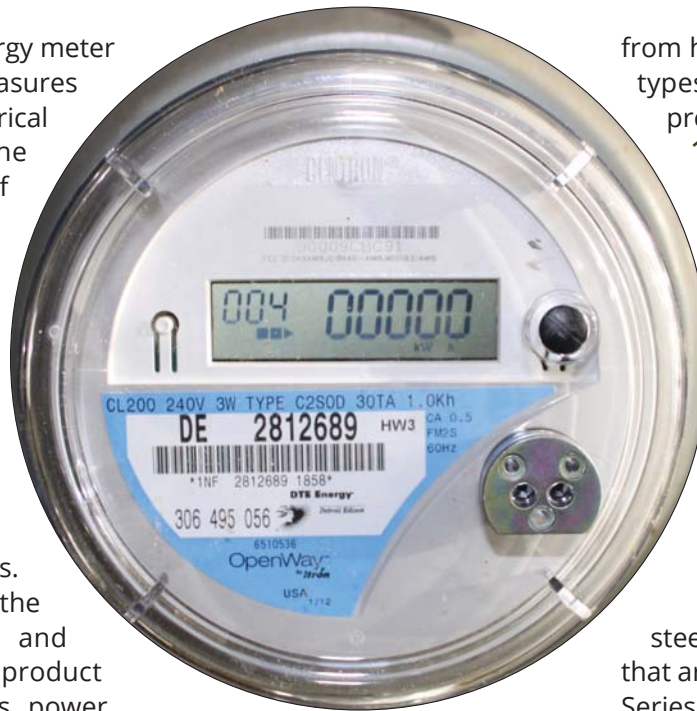

Types of Energy Meter

These may be single phase or three phase meters depending upon the supply utilized by domestic or commercial installation. For small service measurements like domestic customers, these can be directly connected between line and load. But for larger loads, step down current transformers must be placed to isolate energy meters

from high currents. Basically three types of energy meters are present.

1. Electro Mechanical Induction Type Energy Meter

It consists of rotating aluminum disc mounted on a spindle between two electro magnets. Speed of rotation of disc is proportional to the power and this power is integrated by the use of counter mechanism and gear trains.

It comprises of two silicon steel laminated electromagnets that are shunt and series magnets. Series magnet carries a coil which is few turns of thick wire connected in series with line. Series magnet produces the flux which is proportional to the current flowing. Whereas shunt magnet carries coil with many turns of thin wire connected across the supply and produces the flux proportional to the voltage. These two fluxes lag by 90 degree due to inductive nature. The interaction of these two fields produce eddy current in the disk, exerting a force, which is

Photo Courtesy: Dwight Burdette, Wikimedia Commons

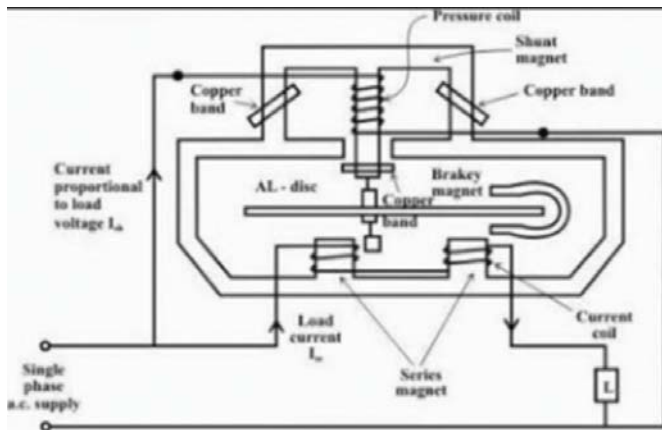

Figure 1: Electro mechanical induction type energy meter proportional to product of instantaneous voltage, current and phase angle between them.

Braking magnet is a permanent magnet which applies the force opposite to normal disc rotation to move the disc at balanced position and to stop the disc while power is off.

Vertical spindle of the aluminum disc is connected to gear arrangement which records a number, proportional to the number of revolutions of the disc, this gear arrangement sets the number in a series of dials and indicates energy consumption over a time. This type of meter is simple in construction and accuracy is somewhat less due to creeping and other external fields. A major problem with these type of meters is their easy prone to tempering, leading to a requirement of an electrical energy monitoring system. These are very common used in domestic and industrial applications.

Advantages of Electro Mechanical Induction type Energy meter

- No moving iron.
- High torque is to weight ratio.
- The moving element has no electrical contact with the circuit.
- Less affected by stray magnetic field.
- Good Damping.

Disadvantages of Electro Mechanical Induction type Energy Meter

- Without proper compensation measures, a considerable amount of errors are caused in the measurement due to temperature, waveform and frequency change.
- Induction meters can be used only for AC measurements.
- They consume a considerable amount of power.
- They have nonlinear scales.

Application of Electro Mechanical Induction type Energy Meter

Electromechanical induction type energy meters are universally used for energy measurements in homes and industries. Government and energy companies charge customers according to these readings. They are cheap to manufacture and very accurate. With some modification they are being used in measuring electricity going to machines in factories.

2. Electronic Energy Meter

Electronic Energy Meter is based on Digital Micro technology (DMT) and uses no moving parts. So the electronic energy meter is known as Static Energy meter. In Electronic energy meter the accurate functioning is controlled by a specially designed IC Called Application specified integrated circuit (ASIC). ASIC is constructed only for specific applications using embedded system technology.

In addition to ASIC, analogue circuits, voltage transformer, current transformer etc. are also present in Electronic energy meter to sample current and voltage. The input data (voltage) is compared with a programmed Reference Data (voltage) and finally a "voltage rate" will be given to the output. This output is then converted into digital data by the Analogue-

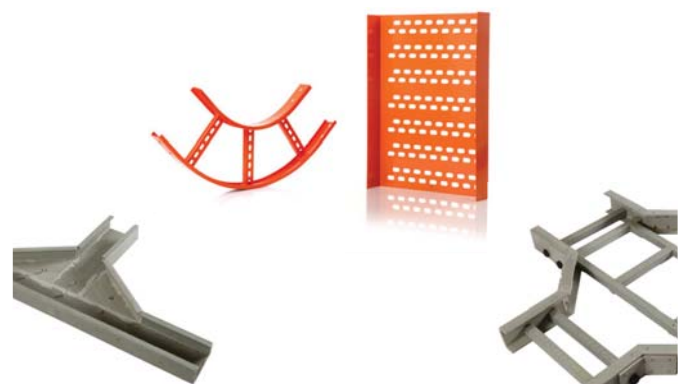

MANUFACTURER OF INDUSTRIAL CABLE TRAYS
PRODUCTS FOR ELECTRICAL APPLICATIONS

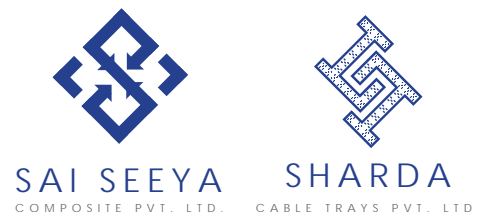

Shade No. 01, Gat No. 607, Radhika Ware House, Pune Satara Road,
Before Kailas Bhel, Velu Phata, Tal - Bhor, Pune - 412205, Maharashtra, India.
+91 77750 95888 | +91 88888 57479
shardacabletrays15@gmail.com | sales@shardacabletrays.com
www.saicabletrayindia.com | www.frpcabletrays.com

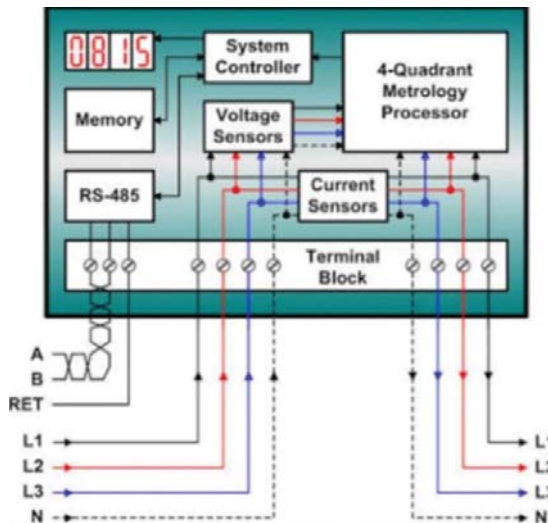

Figure 2: Electro energy meter

Digital converter presented in the ASIC.

The Digital Data is then converted into an Average Value. Average value\mean value is the measuring unit of power. The output of Analogue-Digital Converter is available in pulses indicated by the Light Emitting Diode (LED) placed on the front panel of Electronic energy meter. These pulses are equal to average Kilo Watt Hour (kwh\unit). Different ASICs with various Kwh are used in different makes of EEMs. The output pulses are indicated through LED. The ASIC are manufactured by Analogue Device company. ADE 7757 IC is generally used in many countries to make EEMs.

Advantage of Electronic Energy Meter

- Better accuracy.
- Low current performance.
- Low voltage performance.
- Difficult to temper.
- Digital display.

Disadvantage of Electronic Energy Meter

- Incorrect magnitudes of fluxes.
- Incorrect phase angles.
- Change in strength of brake magnet

- Change in disc resistance
- Abnormal friction of moving parts

Application of Electronic Energy Meter

Modern solid state electronic energy meters are recently developed electronic components to measure electrical energy. Measurement accuracy of the electronic meter is about an order of magnitude better than that of a mechanical meter, while power consumption is lower by about two orders of magnitude.

The electronic energy meter is also better protection against tampering than its mechanical predecessor, and units for prepaid operation (e.g., card readers) and remote meter reading (e.g., wireless, telephone line, or internet) can easily be included.

3. Smart Energy Meters

It is an advanced metering technology involving placing intelligent meters to read, process and feedback the data to customers. It measures energy consumption, remotely switches the supply to customers and remotely controls the maximum electricity consumption. Smart metering system uses the advanced metering infrastructure system technology for better performance. These are capable of communicating in both directions. They can transmit the data to the utilities like energy consumption, parameter values, alarms, etc. and also can receive information from utilities such as automatic meter reading system, reconnected\disconnected instructions, upgrading of meter software's and other important message. These

meters reduces the need to visit while taking or reading monthly bill. Modems are used in these smart meters to facilitate communication systems such as telephone, wireless, fiber cable, power line communications. Another advantage of smart metering is complete avoidance of tampering of energy meter where there is scope of using power in an illegal way.

Advantages of Smart Energy Meters

- Eliminating manual meter readings.
- Monitoring the electrical system more quickly.
- Providing real time data useful for balancing electrical load and reducing power outages.
- Making it possible to use power resources more efficient.
- Avoiding the capital expense of building new power plants.

Disadvantages of Smart Energy Meters

- Transitioning to new technology and processed.
- Managing public reaction and customer acceptance of the new meters.
- Managing and storing vast quantities of metering data.
- Ensuring the security of metering data.

Applications of Smart Energy Meters

Smart energy meter is an important device to manage electricity usage. It collects information of power outage from the appliances and communicates this information to the utility center. 



Munazama Ali

Assistant professor,
Islamic University of
Science & Technology,
Kashmir



SUBSCRIBE MEDICAL EQUIPMENT AND AUTOMATION MAGAZINE



 HELLO

Are you inquisitive to know,
when you have an ailment and you have been prescribed
tests and surgeries.....



WHAT HAPPENS TO YOUR BODY??
HOW DO THE MACHINES WORK??
WHAT DO THE EXPERTS HAVE TO SAY ABOUT IT??



Your search
ends here...

To **Subscribe** flip this page and we have a detailed subscription form for you to fill and send to us or To subscribe online simply go to our website : www.charvypublications.in

SUBSCRIBE



Medical Equipment & Automation

Subscription Offers

Sub. Period	No. of Issues	Subscription Type					
		Print		Digital		Print+Digital	
		Actual Rate	You Pay	Actual Rate	You Pay	Actual Rate	You Pay
1 Year	6	750.00		750.00		1500.00	1125.00
2 Years	12	1500.00	1350.00	1500.00	1350.00	3000.00	2025.00
3 Years	18	2250.00	2000.00	2250.00	2000.00	4500.00	3000.00
5 Years	30	3750.00	3000.00	3750.00	3000.00	7500.00	4500.00

**MAGAZINE WILL BE SENT BY REGISTER PARCEL --Rs.220/YEAR
KINDLY ADD POSTAGE CHARGES IN SUBSCRIPTION AMOUNT**

Subscription / Renewal Form

To,
The Subscription in-charge
MEDICAL EQUIPMENT AND AUTOMATION
Email: sub@charypublications.in

Are you a Subscriber,
Please submit your Subscription no:

Yes, I would like to Subscribe/renew **Medical Equipment & Automation** for _____ years at ₹ _____.

PAYMENT DETAILS :

Cheque / DD No. _____ Dated _____ Drawn on Bank _____
_____ Branch _____ in favour of Chary Publications Pvt. Ltd.

Bank details for NEFT / RTGS / IMPS : Account Name: Chary Publications Pvt. Ltd.

Bank Name: Bank of India Branch: Chembur, Mumbai - 400 071 Account Type: Current Account
IFSC Code: BKID0000009 Bank A/C Number: 000920110000322 SWIFT CODE :BKIDINBBCHM

Name: _____
Company: _____ Designation: _____
Address: _____
_____ City: _____ Pin: _____
Telephone: _____ Mobile: _____
Email: _____
Signature: _____

Stamp

905-906, The Corporate Park, Plot No. 14 & 15, Sector 18, Opp. Sanpada Railway Station, Vashi, Navi Mumbai - 400 703.
Phones: +91 22 27777 170 / 171 • Email: sub@charypublications.in • Contact : Priyanka Alugade • +91 22 27777182 / +91 8652142057

Mahindra Powerol Launches New Range of High Power Diesel Generators



They are turbocharged and air-to-air charge cooled with certifications up to Euro Stage IIIA/U.S. EPA Tier 3 and to India's CPCB-II emissions standards. Developed from a proven heavy-duty industrial base, the engines offer superior performance and reliability. These engines are an ideal choice for customers looking at prime and standby power DG range of 400-625 kVA.

The new range of DG Sets is equipped with Mahindra's unique DiGi-SENSE technology which makes it a Smart DG. The performance of Smart DG sets can be monitored real-time remotely from anywhere, thereby, improving

Mahindra Powerol, a business unit of the USD 19 billion Mahindra Group, announced the extension of its higher kVA Diesel Generators (DG) range with the launch of the 400/500/625 kVA DG powered by Perkins® 2000 series engines. Designed at its R&D hub at Mahindra Research Valley in Chennai and manufactured at its Chakan plant near Pune, this new range of Generator sets with 12.5 Litre to 18 litre Perkins engine is the latest addition to Mahindra Powerol's higher kVA product series.

Perkins® 2000 Series electronic engines are renowned in the market for their world class quality and efficiency.

the uptime of the DG Sets.

Primarily, a service driven industry, the purchase decision of DG sets depends on service network and after sales service commitment. Mahindra Powerol DG sets are supported by one of the widest service networks of more than 200 dealers with over 400 touch points nationally.

The centralized call centre alert 24x7 is very well equipped to provide immediate support to the customer. The team of experts can help to choose the most optimal and well-suited solution to help the customer in the least time possible. ❶

Wish to Subscribe... Flip page to

34

Electrical India

46

Cooling India

64

Lighting India

76

Medical Equipment & Automation

WAGO EPSITRON® - Advanced Power Supply System

WAGO offers uninterruptible power supplies (UPS), buffer modules, redundancy modules and a wide range of electronic circuit breakers (ECBs) as a complete system for seamless upgrades...



WAGO's efficient power supplies always deliver a constant supply voltage – whether it's for simple applications or for automation with greater power requirements. WAGO also offers DC-UPS, buffer modules, redundancy modules and a wide range of electronic circuit breakers (ECBs) as a complete system for seamless upgrades.

EPSITRON® PRO / CLASSIC Power

Applications with high output requirements call for professional power supplies capable of reliably handling power peaks. WAGO's PRO and CLASSIC Power Supplies are ideally suited for such applications. (Output Voltages – 12/24/48VDC)

EPSITRON® ECO Power

Many basic applications only require 24 VDC, it is economically possible with WAGO's ECO.

EPSITRON® COMPACT Power

WAGO's compact, high-performance EPSITRON® COMPACT Power Supplies in DIN-rail-mount housings are available with output voltages of 5, 12, 18 and 24 VDC, as well as nominal output currents up to 6.5 A.

EPSITRON® – DC/DC Converters

Instead of using an additional power supply,

WAGO's EPSITRON® DC/DC Converters are ideal for specialty voltages, allowing sensors and actuators to be reliably supplied.

EPSITRON® – Uninterruptible Power Supply (UPS)

Consisting of a 24 V UPS charger and controller with one or more connected batteries, WAGO's Uninterruptible Power Supply reliably powers an application for several hours. Integrated display and RS-232 interface (option) simplify visualization and configuration and Battery control technology for predictive maintenance extends battery life.

EPSITRON® – Capacitive Buffer Modules

WAGO's EPSITRON® Capacitive Buffer Modules offer power reserves that may be required when starting heavy motors or triggering a fuse. It has got decoupled output: integrated diodes for decoupling buffered loads from unbuffered loads

EPSITRON® – Redundancy Modules

WAGO's redundancy modules are ideal for reliably increasing power supply availability. Solutions for 12, 24 and 48 VDC supply, up to 76 A supply: suitable for nearly every application

EPSITRON® – Electronic Circuit Breakers (ECBs)

WAGO's 1-, 2-, 4- and 8-channel ECBs with fixed or adjustable currents ranging from 0.5 to 12 A are the space-saving and precision solution for fusing DC voltage circuits.

Usage of Quality Analysers for Permanent PQ Monitoring & Reporting

In recent times, Power Quality (PQ) monitoring has become a necessity for most in progress oriented utility companies. After deregulation of energy sector, suppliers of electric energy are mostly private companies where shareholders require profit. This can lead to fewer investments into infrastructure which influences quality of supply. Therefore, regulator requires reporting about PQ from utility companies to supervise overall situation regarding PQ. On the other hand, utility companies are interested in receiving electric energy of proper quality as defined in contract with bidder.

For the purpose of formal PQ monitoring and reporting as is required by a regulator the following is needed:

1. PQ analysers that are capable of measuring PQ parameters with certified Class A accuracy and that are capable of performing analysis according to standard EN 50160. Features like transient and waveform recorder are useful, but not required by a regulator

2. System solution for wide area PQ monitoring that collects standardized weekly PQ reports and detailed data about anomalies with precise time stamps
3. Possibility to automatically send proper annual PQ reports to regulator and to collect and present PQ reports and anomalies of required date and time to customers when/if needed

A system solution suggested by company ISKRA incorporates PQ analyser MC774 and MC784 which is certified class A analyser and an advanced web based software MiSMART, which automatically collects PQ reports, anomalies and other measurements of interest from all analysers connected into system.

Such system is already used by several utility companies, and since it is not a standalone application, it can be easily modified to suit customers' demands without need to reinstall application or to stop normal operation. 

ISKRA, D.D., Slovenia



Green Power
Earthing Solutions PVT.LTD.
ISO-9001-2015 Company



Backfill Compound

- GI Earthing Electrode
- Copper Bonded Rod
- Copper Bond Electrode
- Pure Copper Electrode

Works / Office : Plot No.9, Padmavati Nagar, Railway Station
Hathkangle, Dist Kolhapur.M.8007116007



Earthing PIT Cover



Earthing PIT Cover



Green Power
Earthing Solutions PVT.LTD.

Works / Office : Plot No.9, Padmavati Nagar, Railway Station
Hathkangle, Dist Kolhapur
Mob. 7798984177, 9823449777, 9765383777, 8007116007
E-mail : kopgreenpowerearthings@gmail.com
jyotiprakash.electrical@gmail.com

EPCOS AC Motor Capacitors Become BIS Compliant

TDK Corporation announces that its subsidiary, EPCOS India Pvt Ltd, fulfills all requirements of the Bureau of Indian Standards (BIS) for AC motor capacitors, which has been verified by accredited laboratories. The company has received an ISI license number (7800031911) according to the IS 2993:1998 standard, and all EPCOS AC motor capacitors now bear the ISI marking.

"We appreciate this policy initiative by the Government of India and efforts undertaken by the BIS toward creating a safe environment for use of electrical and electronic items. The BIS mandate also ensures that there is a level playing field with respect to the specifications with which a product is produced. With India being one of our key markets, it is critical for us to obtain these certifications as per the new norms, and we are happy to be one of the first few capacitor manufacturers to do so," said Mr. Balakrishnan, MD, EPCOS India.



Through its full compliance with BIS mandate, EPCOS India has underscored its reputation of being a leader in the Indian electronic components market by not only carrying the ISI marking, but also by ensuring that these ISI-marked capacitors are already available for customers. In fact, some EPCOS PFC capacitors are already BIS compliant and have been carrying the ISI marking for the past several years. **■**

For further information, visit: <https://en.tdk.eu>

New igus e-chain Cables for Seventh Axis on Fanuc Robots

To use industrial robots efficiently in large production plants, they often need to move in a straight line on a seventh axis. It is important to ensure safe energy supply along the axis from the switch cabinet to the robot. For this purpose, igus has now further expanded its range of e-chain cables for robots with two PUR hybrid cables - CFSPECIAL.792.015 and CFSPECIAL.792.016. The new chainflex cables are highly flexible and designed for use on Fanuc robots.



The cables designed specifically for the 7th axis on Fanuc robots are designed and tested for highly dynamic applications in production plants with long travels. (Source: igus GmbH)

with long travels. On long distances along the seventh linear axis, it is especially important for the cables to avoid failures due to corkscrewing. The new PUR hybrid cables CFSPECIAL.792.015 and CFSPECIAL.792.016 meet the electrical and technical requirements of the Fanuc robots and also meet the high mechanical requirements for highly dynamic applications in long, gliding travels in production systems.

New hybrid cables for robots: tested and with guarantee

The new chainflex special cables for Fanuc robots are shielded and have an abrasion-resistant PUR outer jacket. The

cables are very impact-resistant, flame-retardant and halogen-free. The special cables are also resistant to oil and coolant, as well as to hydrolysis and microbes. Like all igus cables, these chainflex cables were also tested under real environmental conditions in our in-house test laboratory spread over a floor area of 2750 square metres. Therefore, igus is the only provider on the market that can promise a guarantee of 36 months on its cables. **■**

For further information: www.igus.in

ABB Launches World's First Digitally Integrated Power Transformer

The ABB Ability™ Power Transformer, unveiled at the 2018 Hanover Fair, in Germany, will be the world's first integrated solution for digitally enabled power transformers, fundamentally changing the transformer paradigm. All power transformers leaving ABB factories will soon come enabled with digital capabilities, enabling remote monitoring and data analytics of its vital parameters in real time. This will enhance reliability and enable higher utilization of grid assets and power networks.

The transformer will come equipped with a digital hub that can leverage a portfolio of smart devices on a modular platform with plug-and-play capabilities. This modularity and scalability makes the system future-proof while giving users full control over their digital journey.

"The ABB Ability™ Power Transformer solution is a game changer. In addition to providing actionable



intelligence at the local level, it will enable users to leverage the full ecosystem of software solutions and services at the station and enterprise levels, such as our industry leading ABB Ability™ Ellipse® Asset Performance Management System", said Claudio Facchin, President of ABB's Power Grids division. "In addition to enhancing efficiency and product life, the new digital capability will boost reliability and mitigate outages through preventative action."

ABB is also showcasing its recently introduced ABB Ability™ TXpert™ distribution transformer, the world's first digital distribution transformer. TXpert provides intelligence to maximize reliability, optimize operating and maintenance costs and manage the asset more efficiently, building on the ABB Ability™ platform and connected devices to generate actionable intelligence. This product is the first of its kind to integrate sensing technology directly into the transformer during the manufacturing process, resulting in higher accuracy. [®]



WELCOME WORLD ENGINEERING SERVICES

Design, Engineering, Manufacturing, Export of Cable Tray, Raceways, Grating, Earthing Materials & Lightning Protection System for Pan India / Other Country.

Pick for best @ Mobile No. +91 9811237211 / 9811600086 • email: rajeev@welcomeworldeng.com

Welcome
World
Concept of
Safety &
Electrical
Engineering
up to
next level



Cable Tray & Accessories

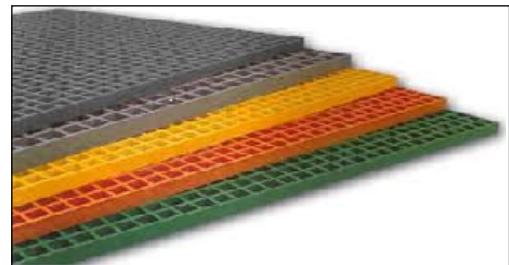

FRP Grating

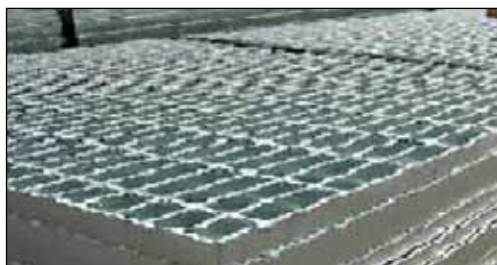

Hot Dip Galvanized Grating



Earthing Materials & Lightning

Kusam-Meco AC/DC TRMS Digital Clampmeter

KUSAM-MECO has introduced a new AC/DC TRMS Digital Clampmeter Model KM 2777. It meets the requirements for CAT IV 1000V AC & DC & is UL Approved. It has features, functions & ranges never seen before in one Digital Clamp-on Multimeter. It has 3-5/6 digits 6,000 + 3-1/2 digits 1,999 counts Dual LCD display with 5/sec update rate. Its jaw size is 55mm. It measures AC & DC Current upto 2000 Amps. It can measure fundamental voltage & frequency of most Variable Frequency Drives (VFD). An additional feature is Non-Contact-EF Detection. For precise indication of live circuits, it has probe contact EF detection function also.



with high impedance, also it can measure Noisy High Voltage AC Frequencies upto 1999Hz in dual display. It has capacitance measurement function upto 2000 μ F. It can do continuity tests at very fast speed. It has PC interface capability with optional purchase of USB Cable software.

It has AC/DC voltage, AC+DC voltage, AC/DC current (clamp on), autocheck DCV, autocheck ACV, VFD ACV, Ohm & Autocheck Ohm, capacitance, temperature, DC + ACA current (clamp on), Hz line level frequency, Non-Contact EF-Detection measurement. It has Diode Test, Continuity Test, Peak Hold, Display Hold, Relative-Zero Mode, Range-Lock & Function-Lock function.

It has transient protection upto 12 KV (1.2/50 μ s) providing excellent protections for those who are safety conscious. It has CAT IV 1 KV High Safety over Voltage Category. The Digital Clampmeter has unbeatable 400 KHz DC + AC Performance & VFD features. It has high basic accuracy of 0.5% (DCV) and Resolution 1mV DC. It has Auto & manual ranging functions except in Hz & Capacitance function range. To provide clear reading of the displayed value in the dark, it has backlight LCD display.

The voltage measurement is upto 1000 V AC/DC

The meter meets the requirements for double insulation per IEC/EN61010-1 2nd Ed, UL61010-1 2nd Ed., & CAN/CSA C22.2 No.61010.1-0.92. This meter operates on standard 1.5V AA Size battery x 2. It's dimension is 264(L) x 97(W) x 43(H) mm & weight about 608g . It is supplied with Carrying Case, Test leads (pair), Operating manual & Bkp60 banana plug K-type Thermocouple x 1. USB interface kit BRUA-19X, BKB32 banana plug to type-K socket plug adaptor is Optional Accessory. **E**

For further information, visit: www.kusamelectrical.com

Meet Dewetron & New Mixed Signal Power Analyzer

DEWETRON launches DEWE2-PA7 Mixed Signal Power Analyzer. The DEWE2-PA7 enables analysis of polyphase EVs and engine behavior with a single system, and a guaranteed basic accuracy of 0.01%. The system is capable of simultaneous analysis of several motors, converters or complete drivetrains – up to 12 power channels.

It is also the only power analyzer with the capability to calculate power parameters, even polyphase motors, up to seven phases per power group. The DEWE2-PA7 combines waveform data, mixed signal and power analysis, while providing reliable, gapless recording of any analog or digital signal and high-performance power calculation of several power groups simultaneously.

Up to 2 MS/s/ch and high dynamic range guarantee data integrity. Smart interface technology makes it easy to integrate a DEWE2-PA7 into automation systems and testbed environments while guaranteeing reliable data transmission, easy-to-use remote control and configuration through



TCP/IP-based protocols in compliance with standardized protocols such as ASAM and file formats.

DEWETRON is synonymous with the development and production of sophisticated measurement systems for energy and power analysis. Our equipment supplies the high precision and comprehensive measurement data necessary your objective decisions. **E**

For further information, visit: www.kew-india.co.in

Energywise - Performance Status All India - Regionwise

Period: Apr-2018 Vis-A-Vis Apr-2017 and Apr-Apr-2018 Vis-A-Vis Apr-Apr-2017

Summary - Thermal, Hydro, And Nuclear (Consolidated)

Category / Sectors	Monitored Capacity (Mw)	Target Apr 2018 to Mar 2019	Generation (Gwh)									
			Apr-18					April 2018 - Apr-2018				
			Program	Actual*	Actual Same Month 2017 - 18	% of Program (4/3)	% of Last Year (4/5)	Program	Actual*	Actual Same Month 2017 - 18	% of Program (9/8)	% of Last Year (9/10)
CENTRAL SECTOR												
THERMAL	64192.91	351607.00	27966.00	31492.60	29450.62	112.61	106.93	27966.00	31492.60	29450.62	112.61	106.93
NUCLEAR	6780.00	38500.00	2508.00	3216.38	3205.10	128.24	100.35	2508.00	3216.38	3205.10	128.24	100.35
HYDRO	14907.72	56176.00	3642.00	2905.50	4739.74	79.78	61.30	3642.00	2905.50	4739.74	79.78	61.30
TOTAL	85880.63	446283.00	34116.00	37614.48	37395.46	110.25	100.59	34116.00	37614.48	37395.46	110.25	100.59
STATE SECTOR												
THERMAL	71989.38	351320.00	28707.00	30465.85	27661.54	106.13	110.14	28707.00	30465.85	27661.54	106.13	110.14
HYDRO	26991.70	61106.00	4388.00	4003.73	4498.57	91.24	89.00	4388.00	4003.73	4498.57	91.24	89.00
TOTAL	98981.08	412426.00	33095.00	34469.58	32160.11	104.15	107.18	33095.00	34469.58	32160.11	104.15	107.18
PVT. SECTOR IPP												
THERMAL	83098.80	369997.00	31895.00	28924.50	30678.05	90.69	94.28	31895.00	28924.50	30678.05	90.69	94.28
HYDRO	2947.00	11418.00	523.00	477.10	832.32	91.22	57.32	523.00	477.10	832.32	91.22	57.32
TOTAL	86045.80	381415.00	32418.00	29401.60	31510.37	90.70	93.31	32418.00	29401.60	31510.37	90.70	93.31
PVT. SECTOR UTL.												
THERMAL	3477.00	18576.00	1589.00	1740.25	1779.35	109.52	97.80	1589.00	1740.25	1779.35	109.52	97.80
HYDRO	447.00	1300.00	104.00	136.00	114.37	130.77	118.91	104.00	136.00	114.37	130.77	118.91
TOTAL	3924.00	19876.00	1693.00	1876.25	1893.72	110.82	99.08	1693.00	1876.25	1893.72	110.82	99.08
TOTAL PVT	89969.80	401291.00	34111.00	31277.85	33404.09	91.69	93.63	34111.00	31277.85	33404.09	91.69	93.63

*Provisional based on Actual-Cum-Assesment

Source: www.cea.nic.in

One Media, Many Platforms



Print

+



Digital

PRINT & DIGITAL
 Advertise in our magazine which is available in both print as well as digital medium



E-NEWSLETTER
 Advertise to avail the weekly digital blast, being on TOP OF THE MIND of your prospective customers is always a manufacturers desire



WEBSITE
 Advertise and get more visibility (hyperlink to your website), increasing hits on your website



Electrical India BRINGING THE POWER INDUSTRY TO YOU SINCE 1961
56 years of dedicated non stop service to the industry

For Package Deals contact, Ad Department at +91 22 27777170 /71 / Yasmeen +91 22 27777196

Tata Power Gears up for Making Maharashtra EV Ready

Tata Power partners with Tata Motors to make Maharashtra EV ready & to establish Electric Vehicle Charging Stations in the State for public use...

Tata Power, India's largest integrated power company, partnered with Tata Motors to make Maharashtra EV ready and to establish Electric Vehicle Charging Stations in the state for public use. Tata Motors Limited has signed a Memorandum of Understanding (MoU) with the Government of Maharashtra to support the Maharashtra Electric Vehicle Policy (2018) in accelerating the adoption of Electric Vehicles in Maharashtra.

Devendra Fadnavis, Chief Minister of Maharashtra, inaugurated the new EV charging stations to mark the week-long World Environment Day celebration. The nine new locations where the EV charging stations have come up include Matunga, BKC, Bhandup (near LBS Marg), Chembur, Malad (near Link Road) and Carnac Bundar (near Fort & Freeway).

Praveer Sinha, CEO & Managing Director, Tata Power, said, "We are committed to making Maharashtra EV ready and Government's vision of providing green technology solutions. We are happy to partner with Tata Motors to deliver on the Government and Group's vision of improving India's carbon footprint and enabling the customers with a sustainable future. We are happy to present Maharashtra with various electric vehicle charging stations that cover the wide expanse of the city. With these installations, Tata Power continues to pursue sustainable practices by using technology to provide Maharashtra customers access to energy-efficient options with ease."

Speaking on the MoU signing initiative, Guenter Butschek, CEO & MD, Tata Motors said, "Tata Motors is committed to the Government's vision of e-mobility in India. We are excited to join forces with the Government of Maharashtra towards this endeavor. We are uniquely positioned to leverage the strength

of our group companies to create an EV ecosystem. With our ready portfolio of EV offerings across our passenger and commercial vehicles, we are geared up to meet future requirements beyond the current tender commitments."

With the launch of nine EV charging stations to mark the World Environment Day, it is Tata Power's endeavour to provide the best of solutions for the country to achieve a greener tomorrow. By using innovative technology, Tata Power is providing customers easy access to energy-efficient processes and facilitating that by setting up charging infrastructure around the city.

With the installation of these Electric Vehicle chargers, the company is working towards removing the range anxiety from people's minds and encouraging them to shift from fossil fuel vehicles to electric vehicles. Tata Power plans to device a mix of fast and regular chargers at these charging stations that will facilitate to charge vehicles from both private and public realms of life. The chargers can also monitor the car battery charging status and units consumed while charging a car.

Being true to the pioneering spirit of the parent group, Tata Power has established the first public Electric Vehicle charging station at Vikhroli in Mumbai.

Being the first to propagate the change towards sustainable energy, Tata Power aims to supplement the government's plan to replace fossil fuel vehicles with electric vehicles by 2030, by installing charging stations at strategic locations.

Since the inauguration of the first station in August 2017, two more were started in January 2018 for public usage at Palladium mall in the Lower Parel area and Phoenix Market City in the Kurla area of the city. 

Forthcoming Events At A Glance

National

7th Edition, Greenco Summit 2018

Venue: ITC Grand Chola, Chennai

Date: 27 - 29 June 2018

Website: www.greenco.in

AUTOMATION EXPO 2018

Venue: BCEC, Goregaon (East), Mumbai

Date: 29 August - 01 September 2018

Website: www.automationindiaexpo.com/

Renewable Energy India 2018

Venue: India Expo Mart, Noida

Date: 20-22 September 2018

Website: www.automationindiaexpo.com/

International

CWIEME BERLIN

Venue: Messe Berlin, Germany

Date: 20 - 22 June 2018

Website: www.coilwindingexpo.com

POWER-GEN & DistribuTECH Africa

Venue: Sandton Convention Centre, Johannesburg, South Africa

Date: 19-20 July 2018

Website: <http://www.wire-southeastasia.com/>

Global Power & Energy Exhibition (GPEX)

Venue: Barcelona, Spain

Date: 17-20 September 2018

Website: <https://gpexevent.com/>

Attn: Advertisers

Dear Valued Advertisers,

Effective 1st July 2017 Goods and Service Tax Act (GST) is applicable on

- i) Advertisements in Print Media @ 5%
- ii) Advertisements on Websites @ 18 %

For any clarification, please contact our accounts department on 022 - 27777 175 or email : accounts@charypublications.in

Company Name	Page No.
Allied Power Solutions	15
Anchor Electricals Pvt. Ltd.	13
Apar Industries Ltd.	51
AVR Electronics Pvt. Ltd.	71
Dynamic Cables Pvt. Ltd.	55
Epcos AG	31
Epcos India Pvt. Ltd.	39
Electrical Research & Development Association	41
Flir Systems India Pvt. Ltd.	29
Galaxy Earthing Electronics Pvt. Ltd.	63
Ganesh Electronics & Electricals	67
Greatwhite Global Pvt. Ltd.	19
Green Power Earthing Solutions Pvt. Ltd.	83
Hager Electro Pvt. Ltd.	3
Havells India Ltd.	21, 23, 25
Hindalco Industries Ltd.	9
HPL Electric & Power Ltd.	47
International Copper Association India	17
ISA Advance Instruments (I) Pvt. Ltd.	61
Jindal Electric & Machinery Corporation	67
Larsen & Toubro Ltd.	IFC
Mahindra & Mahindra Ltd.	7
M&I Material India Pvt. Ltd.	IBC
Nextgen Equipment Pvt. Ltd.	90
R. STAHL Pvt. Ltd.	BC
Riello Power India Pvt. Ltd.	11
Scope T&M Pvt. Ltd.	5
Sharda Cable Trays Pvt. Ltd.	77
Suresh Enterprises	69
Tara Relays	85
Titan Engineering & Automation Ltd.	59
True Power Earthings Pvt. Ltd.	35
Venlite Energy Limited	67
Wago Pvt. Ltd.	43
Welcome Group	85

Electrical Test & Measuring Solutions



Contact Resistance Meter 200A



Turns Ratio Meter



Winding Resistance Meter



Digital Micro Ohm Meter



Current Transformer Tester

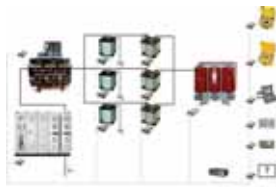

Automatic Transformer Test System



Cast Resin Standard PT



Standard CT



Battery Analyzer



75 KV AC High Voltage Test Set



Automatic Portable HV Tester

OUR PRODUCT RANGE

Winding Resistance Meter
Turns Ratio Meter
Digital Microhm Meter
Contact Resistance Meter
Current Transformer Tester

Standard Current Transformer
Standard Voltage Transformer
Transformer Loss Measuring System
Automatic Transformer Test System
Online DGA

Static Frequency Converter (EPS)
Mobile EPS
High Voltage PD Filters
Coupling Capacitor/ HV Dividers
Online PD Test System

Oil BDV Test Set
AC HV Test Set
AC / DC HV Test Set
Battery Analyzer

Corporate Office: 35-B, Ashiana Duplex, Tandalja, Vadodara – 390012 , Gujarat

Ph : +91 9979888269, +91 9374904404, +91 9811004404 **Email :** info@ngepl.com

SYNTHETIC AND NATURAL ESTER TRANSFORMER FLUIDS

The **MIDEL** family of ester transformer fluids - delivering fire safety and environmental protection to India's power sector.



MIDEL 7131

The world-leading fire safe, biodegradable, synthetic organic transformer fluid, MIDEL 7131 has exceptionally high moisture tolerance, enabling it to extend cellulose insulation life. It is used in a wide range of transformers up to 433kV. Perfectly suited for non-breathing and free-breathing transformers (due to its excellent oxidation stability), MIDEL 7131 offers the ability to safely increase transformer loading or reduce transformer size.



MIDEL eN 1204

MIDEL eN 1204 is a natural ester liquid (rapeseed) with a high fire point that significantly increases fire safety and reduces the need for fire protection equipment. It is sustainably sourced and readily biodegradable, enabling reductions in containment measures. MIDEL eN 1204 has a pour point around 13°C lower than the soya-based natural ester, making it ideal for cooler climates.



MIDEL eN 1215

MIDEL eN 1215 is an excellent dielectric fluid because it has a high fire point, making it demonstrably safer than mineral oil. Environmentally friendly, MIDEL eN 1215 is made from renewable vegetable oil (soya), and is also non-toxic and readily biodegradable. In addition, MIDEL eN 1215 offers superior moisture tolerance and has the potential to increase the lifetime of cellulose based solid insulation, which in turn can extend transformer life.

WHEN IT COMES TO EX PROTECTED ELECTRICAL PRODUCTS AND SOLUTIONS, WE ARE THE BEST.



THE STRONGEST LINK.



SPECIAL SALE: UPTO 70% OFF ON SELECTED & STANDARD PRODUCTS FROM JUNE TO END OF JULY

R. STAHL is a leading manufacturer and supplier of world class flame proof electrical and instrumentation products and solutions such as lighting, automation, installation & control and signaling. All our products are certified by ATEX, IECEx and PESO (selected products).

For enquiries please reach us at:

R. STAHL (P) Ltd. | E.marketing@rstahl.net | **T +91 44 30 600 618** | r-stahl.com